

KARBÜR KALIPÇI FREZE

- Karbür kalıpcı frezeler dakikada 6000-50.000 devire sahip elektrikli veya havalı makinalarda kullanılmalıdır.
- Genel olarak her türlü metal iş parçası işleme ve kesme, polisaj işlemleri, medikal aletlerin işlenmesi için kullanılır.
- Döküm parçaların çapaklarını, dövme ve kaynaklı parçaların temizlenmesi ve çapaklarını yok etmede kullanılabilir.
- Her tür metal kalıp malzemesi için uygundur.
- Karbür kalıpcı frezeler sadece yüksek hızla kullanıldığı durumda, yüksek performans sağlar.

DİŞ FORMLARI



Standart Diş



Kalın Diş



İnce Diş

Çap (mm)	Devir (r/mm)
Ø 3-5	40.000 ~ 50.000
Ø 6-7	30.000 ~ 35.000
Ø 8-9	25.000 ~ 28.000
Ø 10-11	20.000 ~ 23.000
Ø 12-15	15.000 ~ 18.000
Ø 16-25	10.000 ~ 14.000



SKY-A

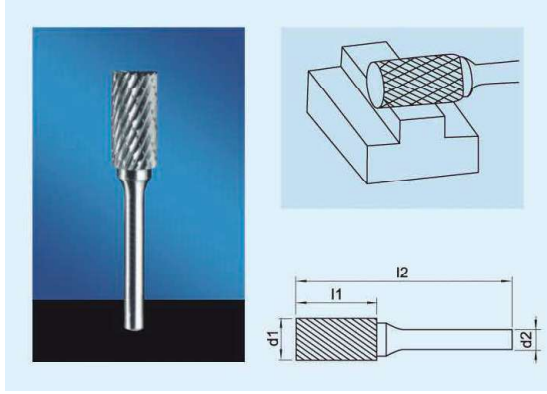

Ürün Kodu	D1	D2	I1	I2
A0413M03	4	3	13	53
A0513M03	5	3	13	53
A0613M06	6	6	13	53
A0616M06	6	6	16	61
A0820M06	8	6	20	64
A1020M06	10	6	25	65
A1225M06	12	6	25	70
A1325M06	13	6	25	70
A1625M06	16	6	25	70

SKY-B

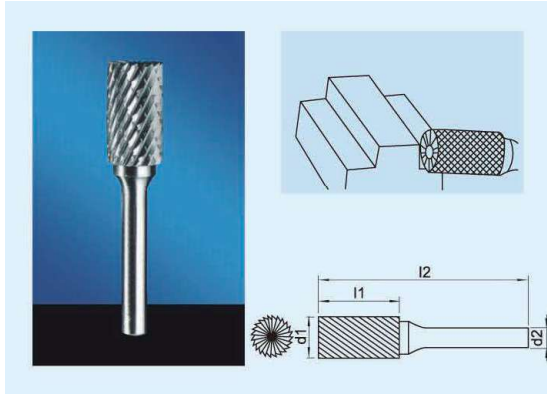

Ürün Kodu	D1	D2	I1	I2
B0314M03	3	3	14	54
B0613M06	6	6	13	53
B0618M06	6	6	18	58
B0818M06	8	6	18	63
B1020M06	10	6	20	65
B1225M06	12	6	25	70
B1625M06	16	6	25	70
B1925M06	19	6	25	70

SKY-C

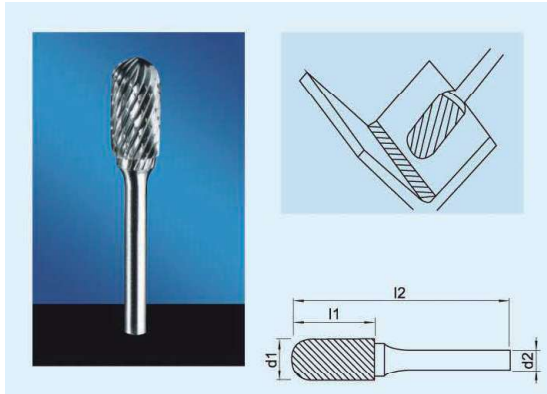

Ürün Kodu	D1	D2	I1	I2
C0413M03	4	3	13	53
C0513M03	4	3	13	53
C0613M06	6	6	13	53
C0616M06	6	6	16	61
C0820M06	6	6	18	63
C1020M06	8	6	18	63
C1225M06	8	6	20	65
C1325M06	10	6	20	65
C1625M06	11	6	25	70
C1225M06	12	6	25	70
C1325M06	13	6	25	70
C1625M06	16	6	25	70

SKY-D

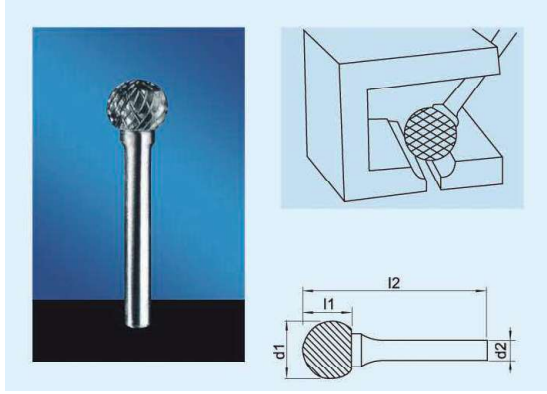

Ürün Kodu	D1	D2	l1	l2
D0404M03	4	3	4	44
D0504M03	5	3	4	44
D0605M03	6	3	5	45
D0807M03	8	3	7	52
D1009M06	10	6	9	54
D1211M06	12	6	11	56
D1311M06	13	6	11	56
D1615M06	16	6	15	60

SKY-E

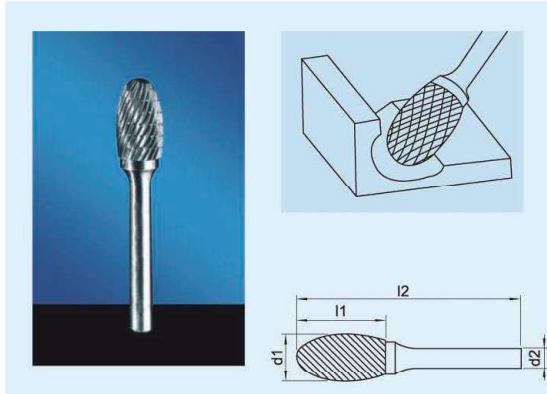

Ürün Kodu	D1	D2	l1	l2
E0407M03	4	3	7	47
E0508M03	5	3	8	48
E0610M03	6	3	10	50
E0813M06	8	6	13	58
E1016M06	10	6	16	61
E1220M06	12	6	20	65
E1322M06	13	6	22	67
E1625M06	16	6	25	70

SKY-F

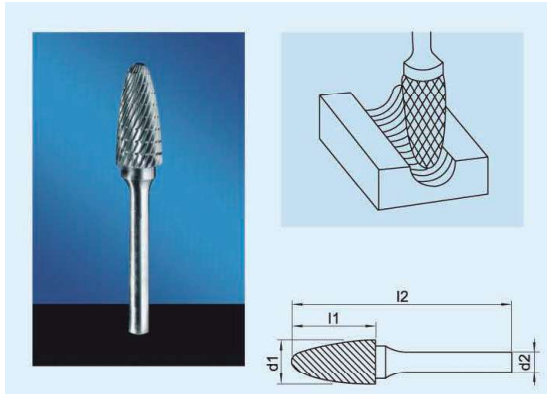

Ürün Kodu	D1	D2	l1	l2
F0413M03	4	3	10	50
F0508M03	5	3	10	50
F0610M06	6	6	10	50
F0813M06	8	6	18	63
F1020M06	10	6	20	65
F1225M06	12	6	25	70
F1325M06	13	6	25	70
F1625M06	16	6	25	70

SKY-G

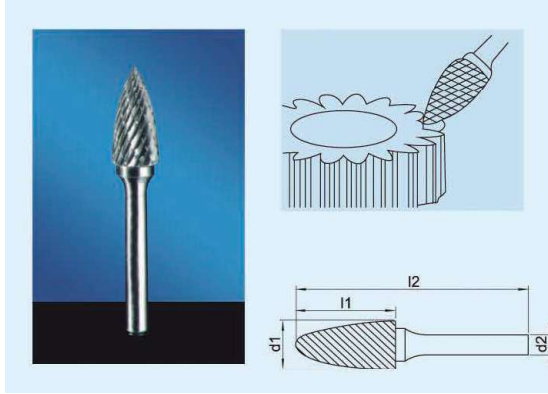

Ürün Kodu	D1	D2	I1	I2
G0410M03	4	3	10	50
G0510M03	5	3	10	50
G0610M06	6	6	10	50
G0818M06	8	6	18	63
G1020M06	10	6	20	65
G1225M06	12	6	25	70
G1325M06	13	6	25	70
G1625M06	16	6	25	70

SKY-H

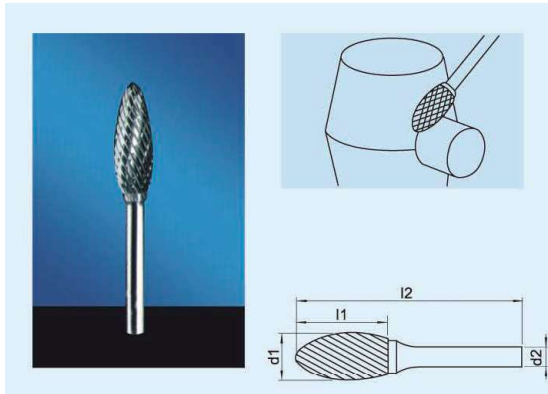

Ürün Kodu	D1	D2	I1	I2
H0513M03	5	3	10	53
H0618M03	6	3	10	58
H0820M03	8	3	20	65
H1025M06	10	6	25	70
H1232M06	12	6	32	77
H1332M06	13	6	32	77
H1636M06	16	6	36	81

SKY-J

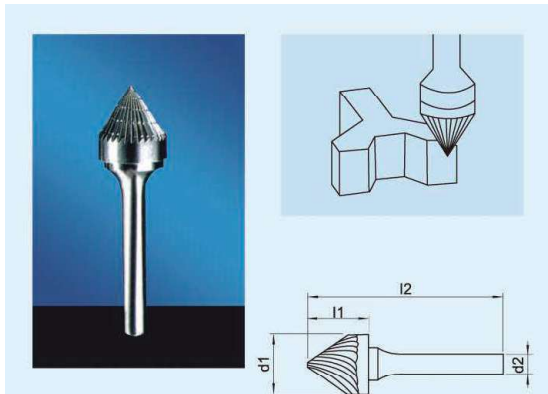

Ürün Kodu	D1	D2	I1	I2
J0405M03	4	3	5	45
J0506M03	5	3	6	47
J0607M06	6	6	7	47
J0809M06	8	6	9	54
J1011M06	10	6	11	56
J1213M06	12	6	13	58
J1617M06	16	6	17	62
J2021M06	2	6	21	66

SKY-L

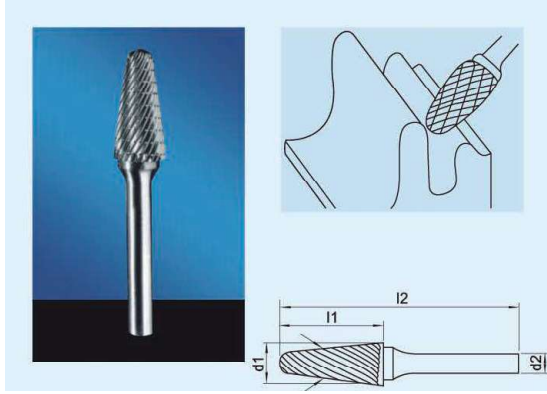

Ürün Kodu	D1	D2	I1	I2
L0416M03	4	3	16	56
L0619M06	6	6	19	64
L0822M06	8	6	22	67
L1025M06	10	6	25	70
L1027M06	10	6	27	72
L1228M06	12	6	28	73
L1328M06	13	6	28	73
L1630M06	16	6	30	75
L1633M06	16	6	33	78

SKY-M

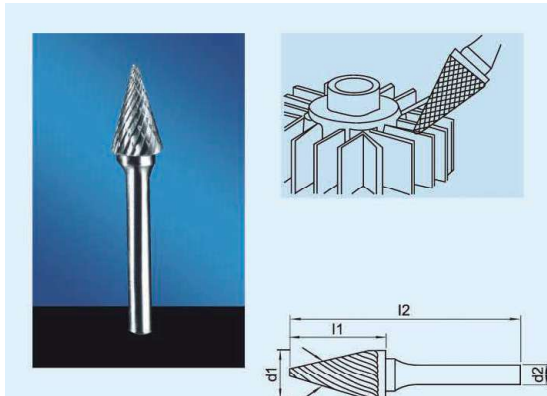

Ürün Kodu	D1	D2	I1	I2
M0413M03	4	3	13	53
M0516M03	5	3	16	56
M0618M06	6	6	18	58
M0818M06	8	6	18	63
M1020M06	10	6	20	65
M1225M06	12	6	25	70
M1325M06	13	6	25	70
M1625M06	16	6	25	70

SKY-K

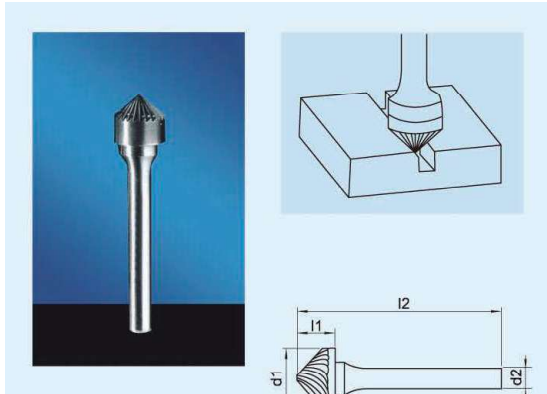

Ürün Kodu	D1	D2	I1	I2
K0603M06	4	3	5	45
K0804M06	5	3	6	47
K1005M06	6	6	7	47
K1206M06	8	6	9	54
K1306M06	10	6	11	56
K1608M06	12	6	13	58

SKY-N

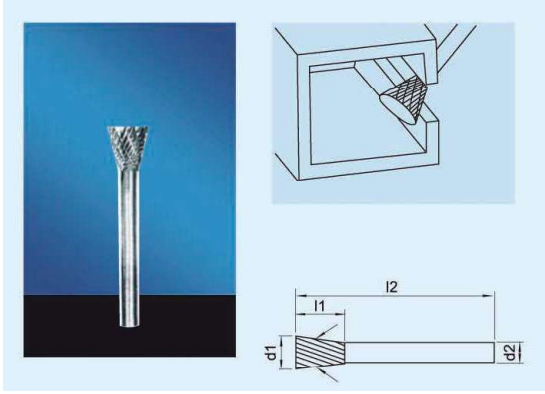

Ürün Kodu	D1	D2	l1	l2
N0405M03	4	3	5	45
N0506M03	5	3	7	46
N0607M03	6	3	7	47
N0809M06	8	6	9	54
N1012M06	10	6	12	57
N1213M06	12	6	13	58
N1616M06	16	6	16	61

SKY-W

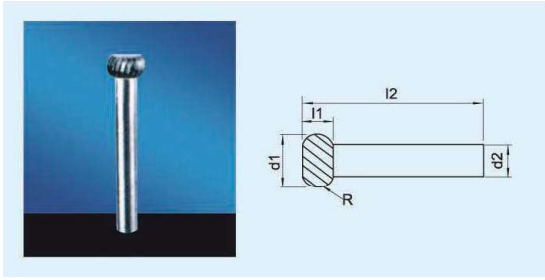

Ürün Kodu	D1	D2	l1	l2
W0614M06	6	3	13	58
W0818M06	8	6	18	63
W1022M06	10	6	22	67
W1225M06	12	6	25	70
W1625M06	16	6	25	70

SKY-X

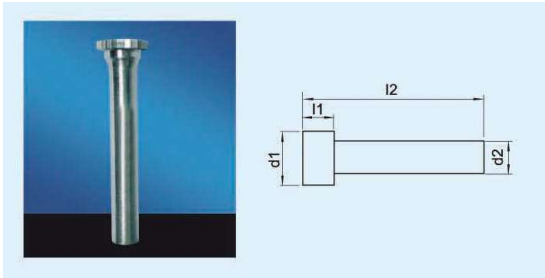

Ürün Kodu	D1	D2	l1	l2
X1202M06	12	6	2	47
X1602M06	16	6	2	47
X1603M06	16	6	3	48
X2505M06	25	6	5	50

SKY-Y

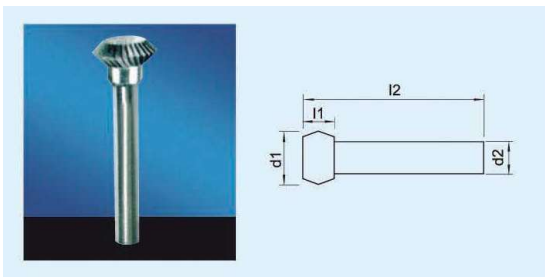

Ürün Kodu	D1	D2	l1	l2
Y1603M06	16	6	3	48
Y2505M06	2	6	5	50

KARBÜR KALIPÇI FREZE 10 PARÇA SET



TEC10D-06M06	A0616M06	C0616M06	D0606M06	E0613M06	F0610M06
	G0610M03	H0820M06	J0607M06	L0619M06	N0809M06
TEC10D-08M06	A0820M06	C0818M06	D1009M06	E0813M06	F0818M06
	G0818M06	H0820M06	J0809M06	L0822M06	N0809M06
TEC10D-10M06	A1020M06	B1020M06	D1009M06	E1016M06	F1020M06
	G1020M06	H1025M06	J1011M06	L1025M06	N1012M06
TEC10D-12M06	A1225M06	C1225M06	D1211M06	E1220M06	F1225M06
	G1225M06	H1232M06	J1213M06	L1228M06	N1213M06
TEC10D-16M06	A1625M06	C1625M06	D1615M06	E1625M06	F1625M06
	G1625M06	H1636M06	J1617M06	L1630M06	N1616M06

KARBÜR KALIPÇI FREZE 8 PARÇA SET



TEC10D-06M06	A0616M06	C0616M06	D0606M06	E0813M06
	F0610M06	G0610M03	H0820M06	L0619M06
TEC10D-08M06	A0820M06	C0818M06	D1009M06	E0813M06
	F0818M06	G0818M06	H0820M06	L0822M06
TEC10D-10M06	A1020M06	B1020M06	D1009M06	E1016M06
	F1020M06	G1020M06	H1025M06	L1025M06
TEC10D-12M06	A1225M06	C1225M06	D1211M06	E1220M06
	F1225M06	G1225M06	H1232M06	L1228M06
TEC10D-16M06	A1625M06	C1625M06	D1615M06	E1625M06
	F1625M06	G1625M06	H1636M06	L1630M06