

ANMX 08 -13-16 / KABA BOŞALTMA ve FİNİŞ

- Çift yönlü 90° kesici uç slot, yüzey frezeleme ve frezeleme operasyonları için uygundur .
- Yüksek açı dizaynı ile keskin kesici ve güçlü kenar.

ÇİFT TARAFLI 4 KENAR

- Uçlar 2 yönlü ve 4 adet kesici ağız dizaynına sahip olup derin frezeleme işlemlerinde güçlü ve yoğundur.
- Yüksek mukavemet ile birlikte ince işlem yüzeyi gerektiren operasyonlar için uygundur. **(Finiş ve kaba tek uç)**
- Daha yüksek bağlantı güvenliğini oluşturmak için dikey vidalı takım tespit sistemini benimser.
- Kesici ağzın kalın diş dizaynı düşük kesim direnci dizaynıyla birleşince yüksek işlem verimi alınır.
- 0.8 radyüs kalınlığı 10 mm den fazla talaş derinliği garanti eder .
- Takım çapları 16-250 mm'dir. **(Saplı – Tarama –Vidalı)**



Saplı Tarama : Ø 16-20-25 ANMX08
Tarama Kafası: Ø 50-63-80 ANMX13
Saplı Tarama : Ø 32-40 ANMX13
Vidalı Tarama : Ø 32-40 ANMX08
Tarama Kafası: Ø 50-250 ANMX16

Örnek Deneme - 1

	
İş Parçası	304 / Paslanmaz Çelik
Operasyon	Kaba Boşaltma
Uç	ANMX080408-PDR / SKY4125
Kesici Takım	BAN08-1616T2-160

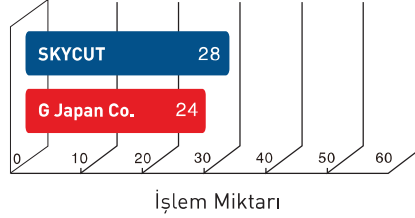

Kesme parametreleri
VC= 110 m / min.
fz= 0,8 mm / t
ap= 1.2 mm
ae= 16 mm

Kesim Ömrü
+17%

Örnek Deneme - 2

	
İş Parçası	45# HRC22
Operasyon	Yüzey Frezeleme/Kuru Kesim
Uç	ANMX160608-PDR / SKY4125
Kesici Takım	BAN16D063T5-22

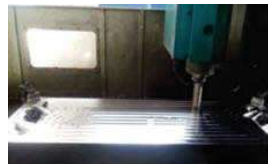
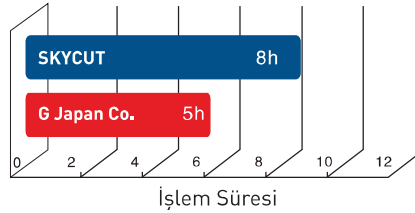

Kesme parametreleri
VC= 180 m / min.
f= 1.34 mm / t
ap= 1.5 mm
ae= 40 mm

Kesim Ömrü
+60%

ONMU - SNEU / YÜZEY FREZELEME

- Çift taraflı 45° derece frezeleme ucu.
- Her tür yüzey frezeleme düzlem işlemine uygun ürün.
- İki farklı kesici ucu aynı takımda kullanma özelliği.

UÇLAR 8 VE 16 KENAR

- Dik vida takım tespit sistemi ile daha iyi bağlantı.
- Etkili dizayn.
- Kare uçlar en fazla 5 mm (SN..).
- Dik uçlar en fazla 3 mm (ON..).
- İki farklı üründe kaba yarı kaba ve ince işlemeye uygundur.
- Takımların tüm yüzeyi kaplama özelliği.
- Takım çapları 50-315 mm'dir.



Örnek Deneme - 1

	
İş Parçası	HT300 / HB230
Operasyon	Yüzey Frezeleme/Kuru Kesim
Uç	ONMU1205ANEN-NM/SKY4125
Kesici Takım	SONFM45D080T06-27

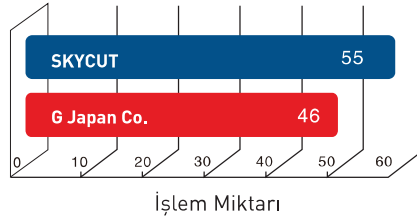

Kesme parametreleri
VC= 200 m / min.
fz= 0.15 mm / t
ap= 3.5 mm
ae= 50 mm



Örnek Deneme - 2

	
İş Parçası	45# HRC22
Operasyon	Yüzey Frezeleme/Kuru Kesim
Uç	SNMU1205ANEN-NM/SKY4125
Kesici Takım	SONFM45D080T06-27

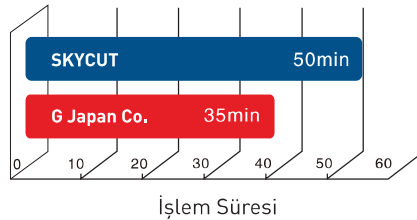

Kesme parametreleri
VC= 250 m / min.
fz= 0.2 mm / t
ap= 2 mm
ae= 25 mm



ODKT / YÜZEY FREZELEME

- Tek taraflı 45° derece frezeleme ucu.
- Her tür yüzey frezeleme düzlem işlemine uygun ürün.
- Yaygın kullanılan kaliteler SKY4115 - SKY4125 - SKY9115
Çelik (P), paslanmaz çelik (M), dökme demir (K), alüminyum iş parçalarında ekonomik yüzey frezeleme

Yüksek kalite alaşımli çelik

Etkili dizayn

Tamamıyla yüzey kaplama

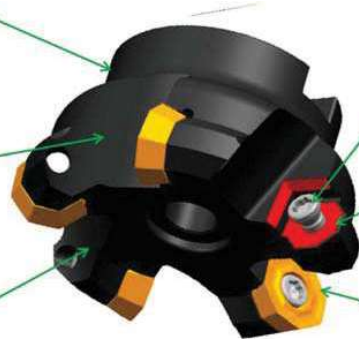

Güçlü vidalama bağlantısı

Pozisyon merkezleme

Ekonomik kesici ağız

Örnek Deneme - 1



İş Parçası	Yüksek alaşımli çelik [1.4839]
Operasyon	Düzlem frezeleme ve finiş
Uç	ODKT060508-NM / SKY4125
Kesici Takım	FM45-D063T05-22-OD06

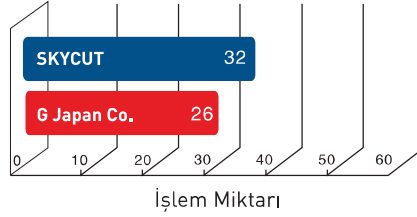

Kesme parametreleri
VC= 100 m / min.
fz= 0,2 mm / t
ap= 1,5 mm
D= 63 mm

Kesim Ömrü
+25%

Örnek Deneme - 2



İş Parçası	45# HRC22
Operasyon	Yüzey frezeleme / Kuru Kesim
Uç	ODKT060508-NM / SKY4125
Kesici Takım	FM45-D080T06-27-OD06

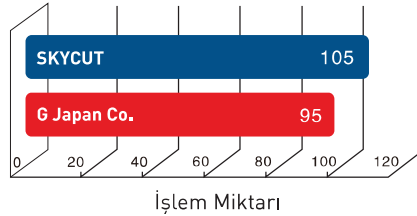

Kesme parametreleri
VC= 130 m / min.
fz= 0,2 mm / t
ap= 0,3 mm
D= 80 mm

Kesim Ömrü
+20%

LOGU - LNMU / YÜKSEK HIZ FREZE SERİLERİ

- Çift yönlü 4 kesici ağız
- Hızlı ve iyi talaş kaldırma performansı
- 90° sağ açılı işleme



Çift yönlü 4 kesici ağız



Hızlı ve iyi talaş kaldırma performansı

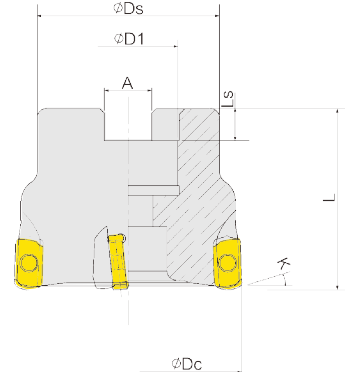
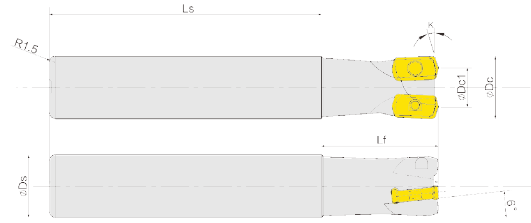
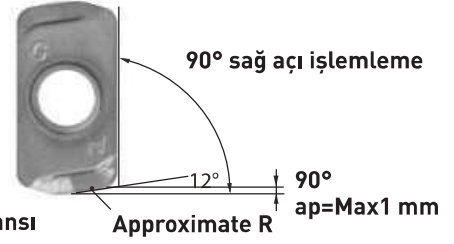

Takım Çapları	Ağız Sayısı	Kullanılacak Uç	f Dc	f D1	f Ds	L	Lf	Ls	K	Vida	Anahtar
										M2.5X7	T-8
EXN03R016M16.0-02	2	LNMU03	16	9.6	16	100	30	70	17°	M2.5X7	T-8
EXN03R020M20.0-03	3		20	13.5	20	130	50	80	17°		
EXN03R025M25.0-04	4		25	18.5	25	140	60	80	17°		
EXN03R032M32.0-05	5		32	25.5	32	150	70	80	17°		
EXN03R0320.32.0-06	6		32	25.5	32	150	70	80	17°		
TXN03R040M160E06	6		40	16	38	40	—	6	17°		
TXN03R050M220E08	8		50	22	47	40	—	7	17°		

WN..08 / 90° KABA BOŞALTMA

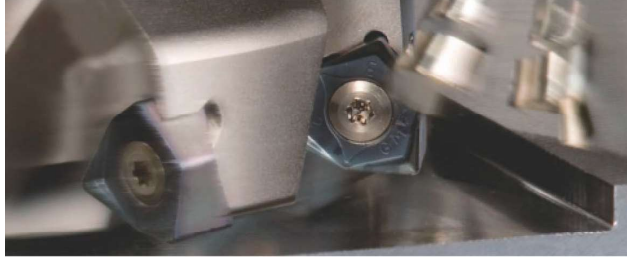

- Çift yönlü 6 ağız kesici uç ve güçlü direnç .
- Güçlü dirençle keskin kenar kesimi.
- Güçlü yapısı ile anti titreşimli seri.

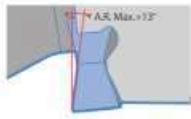

Geniş ön açılı dizayn

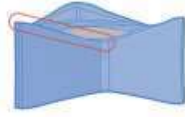

Dinamik eğimli dizayn

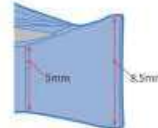



Uç kalınlığı 8.5 mm
Pozisyonlama
5 mm kalınlık

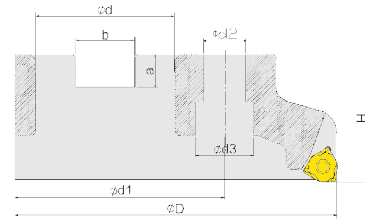
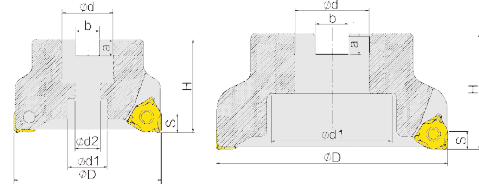

Stabil delik pozisyonu



Takım Çapları	Ağız Sayısı		D	d	D1	d2	d3	H	s	b	a	Vida 	Anahtar 
BWN 050R05A22	5	WN..0806	50	22	17	11	—	40	8	10,4	7	M4X10	T-15
BWN 063R06A22	6		63	22	17	11	—	40	8	10,4	7		
BWN 080R07A27	7		80	27	32	13	—	50	8	12,4	7		
BWN 100R08A32	8		100	32	40	—	—	50	8	14,4	9		
BWN 125R10A40	10		125	40	50	—	—	55	8	16,4	9		
BWN 160R12A40	12		160	40	87	—	—	55	8	16,4	9		
BWN 200R14A60	14		200	60	101,6	18	25	55	8	25,7	14		
BWN 250R16A60	16		250	60	101,6	18	25	55	8	25,7	14		

CN.. - SN.. / KANAL AÇMA UÇLARI

Malafa



Disk



Opsiyonel Spesifikasyon

- Takım çapları: D63-160 mm
- Kesici kanal genişliği: 4-8 mm
- Max. kesim derinliği: 14-41 mm

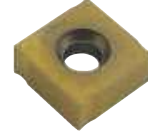

SN.. 3 YÖNLÜ FREZE UCU

- Bağlamsal kenar ile kanal genişliği 4-8 mm arasında değişebilir ve 11-44 mm arasında derinliğinde kesme özelliği .
- 3 yönlü freze ucunun basit ve güvenli bağlanması.
- SN tipi 3 yönlü freze kesicisinin ucu takım vidaları sayesinde hızlandırıldı, yapısı basit ve kullanışlı hale getirildi .
- Ekonomik 4 kenar.
- Ürün seçimi kanal genişliklerine göre seçilir.
- Uç kalınlıkları değişerek 8-11 mm ye kadar kanal açma işleminde kullanılabilir.

Malafa



Disk



Opsiyonel Spesifikasyon

- Takım çapları: D63-160 mm
- Kesici kanal genişliği: 10-12 mm
- Max. kesim derinliği: 11-44 mm



CN.. 3 YÖNLÜ FREZE UCU

- Bağlamsal kenar ile kanal genişliği 10-12 mm arasında değişebilir ve 11-44 mm arasında derinliğinde kesme özelliği.
- 3 yönlü freze ucunun basit ve güvenli bağlanması.
- Ekonomik 4 kenar.
- CN tipi 3 yönlü freze kesicisinin ucu takım vidaları sayesinde hızlandırıldı ve yapısı basit ve kullanışlı hale getirildi.
- 4 kenarlı freze ucunun gücü ve stabilitesi garanti altına almak için uç dikey pozisyonda dizayn edilmiştir.

CN.. - SN.. / KANAL AÇMA UÇLARI

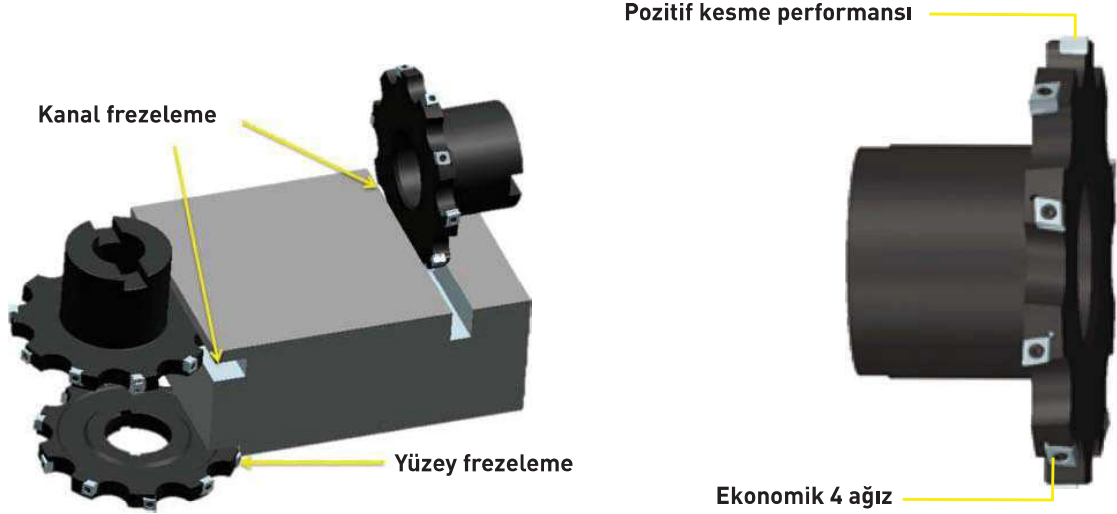

Örnek Deneme - 1

	
İş Parçası	HT250 (HB180-230)
Operasyon	Kanal Frezeleme
Uç	CNEU070508-NM / SKY4125
Kesici Takım	080.H10.06T27-CN07

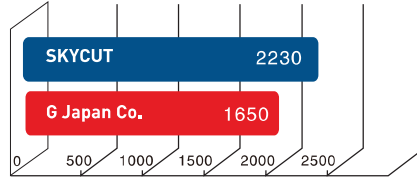

Kesme parametreleri
VC= 220 m / min.
fz= 0,2 mm / t
ap= 3,5 mm
D= 80 mm

Kesim Ömrü
+35%

Örnek Deneme - 2

	
İş Parçası	HT250
Operasyon	Kanal Frezeleme
Uç	CNEU070508-NM / SKY4125
Kesici Takım	125.H10.10T32-CN07

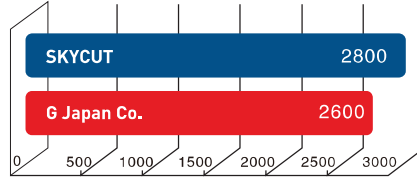

Kesme parametreleri
VC= 220 m / min.
fz= 0,2 mm / t
ap= 3,5 mm
D= 125 mm

Kesim Ömrü
+6%

APMT

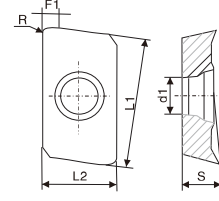

Uç Şekli	Tip	Ölçüler / Boyut (mm)						Kaplama Seçimi						
		L1	L2	S	F1	d1	R	SKY4115	SKY4125	SKY9115	SKY8290	SKY8200	SKY8300	SKY3260
	APMT1135PDER-NL	10.83	6.16	3.50	1.92	2.80	0.80	▲	▲		▲	●	●	●
	APMT1604PDER-NL	16.26	9.26	4.76	2.00	4.60	0.80	▲	▲		▲	●	●	●
	APMT1135PDER-NM	10.83	6.16	3.50	1.92	2.80	0.80	▲	▲		▲	●	●	●
	APMT1604PDER-NM	16.26	9.26	4.76	2.00	4.60	0.80	▲	▲		▲	●	●	●
	APMT1135PDER-NR	10.83	6.16	3.50	1.92	2.80	0.80	▲	▲		▲	●	●	●
	APMT1604PDER-NR	16.26	9.26	4.76	2.20	4.40	0.80	▲	▲		▲	●	●	●
	APGT1135PDRF-AL	10.83	6.16	3.50	1.92	2.80	0.80			▲				
	APGT1604PDRF-AL	16.26	9.26	4.76	2.20	4.40	0.80			▲				

▲ Önerilen kalite (Sürekli stok) ● Sipariş üzerine

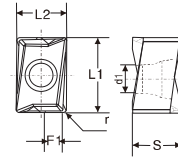

ANMX

Uç Şekli	Tip	Ölçüler / Boyut (mm)						Kaplama Seçimi						
		L1	L2	S	F1	d1	R	SKY4115	SKY4125	SKY3260	SKY8290	SKY8200	SKY8300	
	ANMX080404-PDR	8.60	6.60	5.20	2.50	3.50	0.40	▲	▲	●	●	●	●	
	ANMX080408-PDR	8.60	6.60	5.20	2.50	3.50	0.80	▲	▲	●	●	●	●	
	ANMX130508-PDR	13.70	10.00	8.90	3.40	4.40	0.80	▲	▲	●	●	●	●	
	ANMX130512-PDR	13.70	10.00	8.90	3.40	4.40	1.20	▲	▲	●	●	●	●	
	ANMX160608-PDR	16.70	11.20	10.40	4.70	5.40	0.80	▲	▲	●	●	●	●	
	ANMX160612-PDR	16.70	11.20	10.40	4.70	5.40	1.20	▲	▲	●	●	●	●	



▲ Önerilen kalite (Sürekli stok) ● Sipariş üzerine

3PKT/XPKT

Uç Şekli	Tip	Ölçüler / Boyut (mm)				Kaplama Seçimi					
		ØI.C	T	Ød	Re	SKY4115	SKY4125	SKY3260	SKY8290	SKY8200	SKY8300
	XPKT100404R-M	6,90	4,00	3,80	0,4	●	●	●	▲	●	▲
	XPKT150508R-M	10,70	5,00	4,40	0,8	●	●	●	▲	●	▲
	XPKT190608R-M	13,50	6,00	5,10	0,8	●	●	●	▲	●	▲



▲ Önerilen kalite (Sürekli stok) ● Sipariş üzerine

XNMP/BLMP

Uç Şekli	Tip	Ölçüler / Boyut (mm)				Kaplama Seçimi					
		ØI.C	T	Ød	Re	SKY4115	SKY4125	SKY3260	SKY8290	SKY8200	SKY8300
	XNMP0603R-KM	6,40	3,75	3,20	—	●	●	●	▲	●	●
	XNMP0904R-KM	9,18	4,80	4,50	—	●	●	●	▲	●	●
	XNMP1205R-KM	12,00	5,16	4,60	1,2	●	●	●	▲	●	●
	XNMP1306R-KM	12,30	6,14	5,50	1,2	●	●	●	▲	●	●

▲ Önerilen kalite (Sürekli stok) ● Sipariş üzerine

LNMU/LOGU

Uç Şekli	Tip	Ölçüler / Boyut (mm)				Kaplama Seçimi					
		ØI.C	T	Ød	Re	SKY4115	SKY4125	SKY6200	SKY8290	SKY8200	SKY8300
	LNMU0303EN-GM	6,00	4,3	2,9	1,2	▲	▲	●	▲	●	●
	LNMU0303-ZER	6,00	4,3	2,9	1,2	▲	▲	●	▲	●	●
	LOGU0303-ER	6,2	3,96	3,45	1,0	▲	▲	●	●	●	●

▲ Önerilen kalite (Sürekli stok) ● Sipariş üzerine

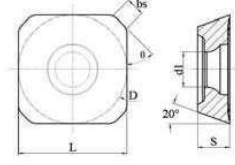



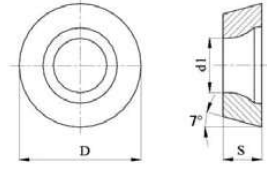

SEET

Uç Şekli	Tip	Ölçüler / Boyut (mm)						Kaplama Seçimi					
		L	D	S	d1	θ	bs	SKY4115	SKY4125	SKY9115	SKY8290	SKY8200	SKY8300
	SEET1204AFEN-NL	12.70	12.70	4.76	5.50	45°	2.50	▲	▲	●	●	●	●
	SEET1204AFEN-NL	12.70	12.70	4.76	5.50	45°	2.50	▲	▲	●	●	●	●
	SEET13T3AGEN-NL	13.40	13.40	3.97	4.40	45°	1.70	▲	▲	●	●	●	●
	SEET13T3AGEN-NM	13.40	13.40	3.97	4.40	45°	1.20	▲	▲	●	●	●	●
	SEET13T3AGSN-NK	13.40	13.40	3.97	4.40	45°	1.30	▲	▲	●	●	●	●
	SEET13T3AGSN-NH	13.40	13.40	3.97	4.40	45°	1.30	▲	▲	●	●	●	●
	SEET13T3AGSN-NG	13.40	13.40	3.97	4.40	45°	1.30	▲	▲	●	●	●	●
	SEET13T3AGFN-AL	13.40	13.40	3.97	4.40	45°	2.20	●	●	▲	●	●	●
	SEET13T3AGFN-NW	7.96	13.40	3.97	4.40	45°	2.20	▲	▲	●	●	●	●

▲ Önerilen kalite (Sürekli stok) ● Sipariş üzerine





RPET/RPEW/RCET/RDMT

Uç Şekli	Tip	Ölçüler / Boyut (mm)				Kaplama Seçimi					
		D	S	d1	θ	SKY4115	SKY4125	SKY3260	SKY8290	SKY8200	SKY8300
	RPET1003MO-NL	10.00	3.18	4.40	11°	▲	▲	●	▲	●	●
	RPET1204MO-NL	12.00	4.76	4.40	11°	▲	▲	●	▲	●	●
	RPET08T2MO-NM	8.00	2.78	2.94	11°	▲	▲	●	▲	●	●
	RPET1003MOT-NM	10.00	3.18	4.40							
	RPMT1003MOT-NM	10.00	3.18	4.40	11°	▲	▲	●	▲	●	●
	RPET1204MO-NM	12.00	4.76	4.40	11°	▲	▲	●	▲	●	●
	RPMT1204MO-NM	12.00	4.76	4.40	11°	▲	▲	●	▲	●	●
	RPET1606MOT-NM	16.00	6.35	5.50	11°	▲	▲	●	▲	●	●
	RPEW08T2MO	8.00	2.78	2.94	11°	▲	▲	●	▲	●	●
	RPEW1003MO	10.00	3.18	4.40	11°	▲	▲	●	▲	●	●
	RPEW10T3MO	10.00	3.18	4.40	11°	▲	▲	●	▲	●	●
	RPMW10T3MO	10.00	3.18	4.40	11°	▲	▲	●	▲	●	●
	RPEW1204MOT	12.00	4.76	4.40	11°	▲	▲	●	▲	●	●
	RPMW1204MOT	12.00	4.76	4.40	11°	▲	▲	●	▲	●	●
	RCET10T3MO-NE	10.00	3.97	4.40	7°	▲	▲	●	▲	●	●
	RCET1204MO-NE	12.00	4.76	4.40	7°	▲	▲	●	▲	●	●

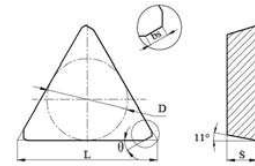
▲ Önerilen kalite (Sürekli stok) ● Sipariş üzerine







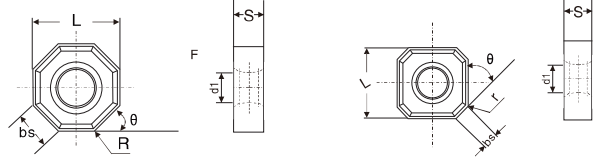

TPKN22/16

Uç Şekli	Tip	Ölçüler / Boyut (mm)					Kaplama Seçimi					
		D	S	d1	θ	bs	SKY4115	SKY4125	SKY3260	SKY8290	SKY8200	SKY8300
	TPKN1603PDR	16.50	9.53	3.18	30°	1.30	●	●	●	▲	●	●
	TPKN2204PDR	22.00	12.7	4.76	30°	1.40	●	●	●	▲	●	●
	TPER1603PDTR-NR	16.50	9.53	3.18	30°	1.30	●	●	●	▲	●	●

▲ Önerilen kalite (Sürekli stok) ● Sipariş üzerine

SNEU/ONMU





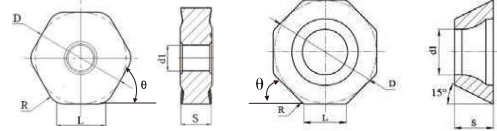

Uç Şekli	Tip	Ölçüler / Boyut (mm)						Kaplama Seçimi					
		L	S	d1	θ	bs	R	SKY4115	SKY4125	SKY9115	SKY8290	SKY8200	SKY8300
	SNEU1205ANEN-NL	12.70	6.35	6.00	45°	2.20	0.80	▲	▲	●	●	●	●
	SNEU1205ANEN-NM	12.70	6.35	6.00	45°	2.20	0.80	▲	▲	●	●	●	●
	SNEU1205ANFN-NL	12.70	6.35	6.00	45°	2.20	0.80	●	●	▲	●	●	●
	SNEU1205ANEN-NW	12.70	6.35	6.00	45°	2.20	0.80	▲	▲	●	●	●	●
	SNMU1205ANER-NM	12.90	5.50	6.00	45°	5.00	0.50	▲	▲	●	●	●	●
	ONMU1205ANEN-NM	12.90	5.50	6.00	45°	5.00	0.50	▲	▲	●	●	●	●

▲ Önerilen kalite (Sürekli stok) ● Sipariş üzerine







ODKT/HNMX

Uç Şekli	Tip	Ölçüler / Boyut (mm)						Kaplama Seçimi					
		L	D	S	d1	θ	R	SKY4115	SKY4125	SKY9115	SKY8290	SKY8200	SKY8300
	ODKT060508-NL*	6.50	15.88	5.56	5.56	45°	0.80	▲	▲	●	●	●	●
	ODKT060508-NM	6.50	15.88	5.56	5.56	45°	0.80	▲	▲	●	●	●	●
	ODKT060508-NR	6.50	15.88	5.56	5.56	45°	0.80	▲	▲	●	●	●	●
	ODKT060508-NL	6.50	15.88	5.56	5.56	45°	0.80	●	●	▲	●	●	●
	HNMX050410-NM	7.10	12.70	5.00	5.00	55°	1.00	▲	▲	●	●	●	●

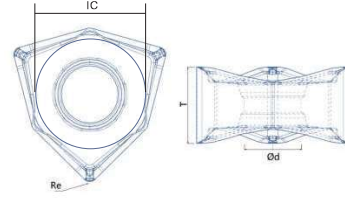
▲ Önerilen kalite (Sürekli stok) ● Sipariş üzerine

WN..08





Uç Şekli	Tip	Ölçüler / Boyut (mm)				Kaplama Seçimi					
		ØI.C	T	Ød	Re	SKY4115	SKY4125	SKY3260	SKY8290	SKY8200	SKY8300
	WNMU080608EN-GM	14.00	8.30	6.35	0.8	●	▲	▲	▲	●	●
	WNEX080608K-XF	12.50	6.40	4.70	0.8	●	▲	▲	▲	●	●
	WNEX080608K-XT	12.50	6.40	4.70	0.8	●	▲	▲	▲	●	●
	WNEX080608K-XM	12.50	6.40	4.70	0.8	●	▲	▲	▲	●	●
	WNEX080616K-XF	12.50	6.40	4.70	1.6	●	▲	▲	▲	●	●
	WNEX080616K-XT	12.50	6.40	4.70	1.6	●	▲	▲	▲	●	●
	WNEX080616K-XM	12.50	6.40	4.70	1.6	●	▲	▲	▲	●	●
	WOGU060408R-M	9.20	4.65	3.70	0.8	●	▲	▲	▲	●	●
	WOGU090508R-M	12.90	6.55	5.16	0.8	●	▲	▲	▲	●	●

▲ Önerilen kalite (Sürekli stok) ● Sipariş üzerine

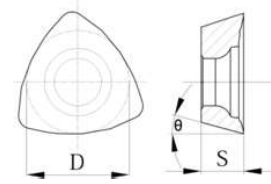
UDET/UDMT





Uç Şekli	Tip	Ölçüler / Boyut (mm)				Kaplama Seçimi					
		D	S	d1	θ	SKY4115	SKY4125	SKY3260	SKY8290	SKY8200	SKY8300
	UDET080308-NM	6.80	3.18	2.94	15°	▲	▲	●	●	●	●
	UDET12T312-NM	9.60	3.97	4.40	15°	▲	▲	●	●	●	●
	UDMT080308T-NH	6.80	3.18	2.94	15°	▲	▲	●	●	●	●
	UDMT12T312-NH	9.60	3.97	4.40	15°	▲	▲	●	●	●	●

▲ Önerilen kalite (Sürekli stok) ● Sipariş üzerine

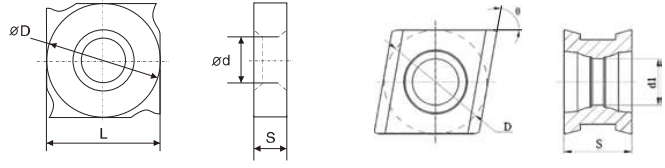
CNEU/SNEX



Uç Şekli	Tip	Ölçüler / Boyut (mm)					Kaplama Seçimi					
		D	S	d1	θ	R	SKY4115	SKY4125	SKY3260	SKY8290	SKY8200	SKY8300
	CNEU070508-NM	7.60	5.00	3.40	80°	0.80	●	▲	●	●	●	●
	SNEX1202-GM	12.70	2.30	5.00			●	▲	●	●	●	●
	SNEX1203-GM	12.70	3.00	5.00			●	▲	●	●	●	●
	SNEX12T3-GM	12.70	3.50	5.00			●	▲	●	●	●	●
	SNEX1204-GM	12.70	4.00	5.00			●	▲	●	●	●	●
	SNEX12T4-GM	12.70	4.50	5.00			●	▲	●	●	●	●

▲ Önerilen kalite (Sürekli stok) ● Sipariş üzerine

QOHX

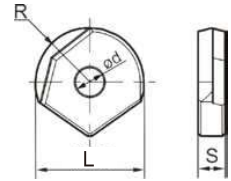

Uç Şekli	Tip	Ölçüler / Boyut (mm)				Kaplama Seçimi					
		L	S	d	R	SKY4115	SKY4125	SKY3260	SKY8290	SKY8200	SKY8300
	P3201-D10	10.00	3.00	4.00	5.00	●	▲	●	●	●	●
	P3201-D12	12.00	3.00	4.00	6.00	●	▲	●	●	●	●
	P3201-D16	16.00	4.00	5.00	8.00	●	▲	●	●	●	●
	P3201-D20	20.00	5.00	5.00	10.00	●	▲	●	●	●	●
	P3201-D25	25.00	6.00	6.00	12.50	●	▲	●	●	●	●
	P3201-D32	32.00	7.00	8.00	16.00	●	▲	●	●	●	●

▲ Önerilen kalite (Sürekli stok) ● Sipariş üzerine