



### ÇELİK - SKY 2225P

#### Nano Kaplama Teknolojisi

- Tek yöndeki kaplama kristalizasyonunu kontrol ederek sertlik artırılabilir ve yüksek hız koşulları altındayken bile mükemmel aşınma direnci sağlanabilir.

#### Güçlü Bağlama Teknolojisi

- Kaplamalar arasındaki bağlanma derecesi üst limitine kadar artırıldı ve ince tabaka ile güçlendirme ve toklaştırma sağlandı.

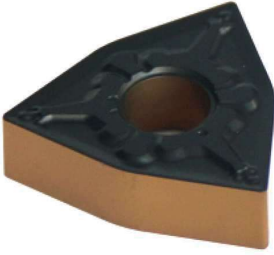

#### Özellikler

Çift renkli kaplama , çok yönlülük, çelik işleme de yaygın olarak kullanılır.



#### Pürüzsüz Kaplama Yüzeyi

Anormal hasar ve dökülmeyi önler.

#### Ultra Kalın Nano Yapı ve İnce Kaplama

$Al_2O_3$   
Yüksek sıcaklıkta üstün aşınma direnci.

#### Güçlü Kombinasyon

Kaplamaların ana katmanının dökülmesini önler.

#### Nano Yapı TiCN

Mükemmel aşınma ve dökülme direnci.

#### Özel Sinterlenmiş Karbür Kaplama Ana Malzemesi

Çatlak büyümesini önler ve stabil ömür sağlar.

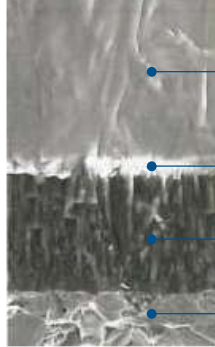

### DÖKME DEMİR SKY 2225K



#### Özellikler

Çift renkli kaplama , çok yönlülük, dökme demir işleme de yaygın olarak kullanılır.



## ÇELİK - SKY4010 / SKY4025

### Özellikler

- Yeni talaş kırıcı tipleri ince işlem yarı kaba kaba
- Yeni kaplama : 4010 -4025
- Kesme kenarlarının polisajlanması
- Çelik işlemede yaygın olarak kullanılır ve aşınma direnci yüksektir .



**NPL**

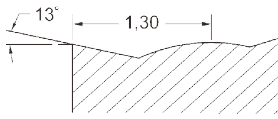

Keskin ön açılı dizaynı ile kısa derinlikte ve yüksek ilerleme işlemlerinde iyi performans verir. Bu da sürekli stabil talaş işlemi elde etmeyi sağlar .

**NG**

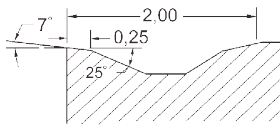

Düşük, kırılma direnci. Uluslararası talaş kırıcı formuna sahiptir.

**NX**

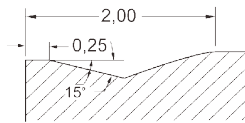

Köşe dirençleri kuvvetlendirilmiş ve tok. Kesintili torna operasyonlarında yarı kaba işlemler için uygundur.

**NH**

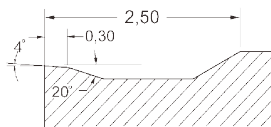

Kaba talaş operasyonlar için uygundur. Düşük direnç ve yüksek ilerleme ile birlikte iyi talaş kırma etkisi elde edilir.

### NFM - PASLANMAZ ÇELİK

#### Özellikler

- Keskin kesici kenar, kesim derinliği yüksek.
- Çift ön açılı dizayn iki yönlü kesme açısı ve yüksek güç.
- Çift açılı talaş kırma kanalı çok yönlülük ile birlikte bir çok koşulda uyum sağlayan talaş kırıcı formudur.

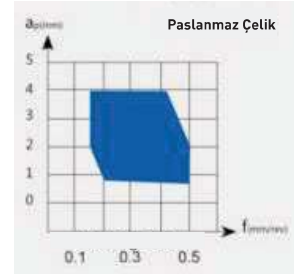
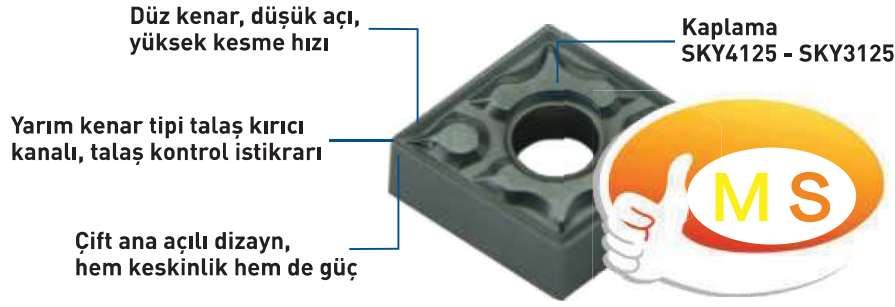
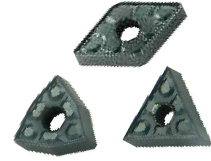
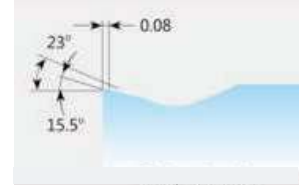

#### Örnek Deneme



İş Parçası	316 (HB200) Paslanmaz Çelik
Operasyon	Dış Çap Yüzey Tornalama
Uç	TNMG160404-NFM / <b>SKY4125</b>

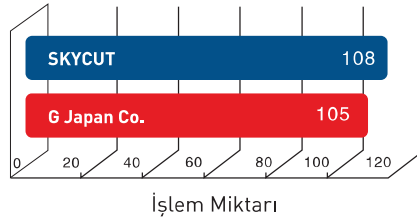

Kesme parametreleri  
VC= 106 m / min.  
f= 0.1 mm / r  
ap= 0.5 mm



## TORNA UÇLARI AÇIKLAMALARI

### NF - PASLANMAZ ÇELİK

#### Özellikler

- NF Serisi kanal, bara ve iç çap operasyonları için uygun talaş kırıcı formudur.

Düz kenar ve düşük açı ile yüksek kesim derinliği ve kesim

İç çapta talaş kontrol istikrarı ve talaş kırıcı kontrolü

Çift ana açılı dizayn, hem keskinlik hem de güç

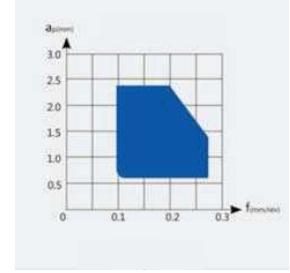
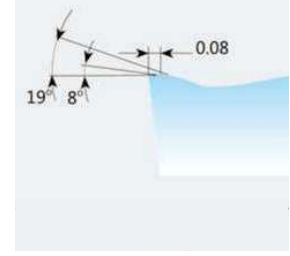

### Örnek Deneme - 1

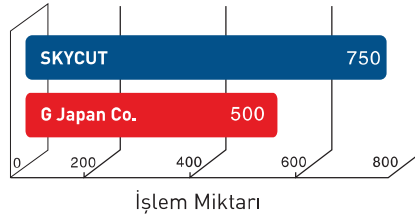

Kesme parametreleri  
VC= 110 m / min.  
f= 0.2 mm / r  
ap= 2 mm

Kesim Ömrü  
**+50%**

### Örnek Deneme - 2

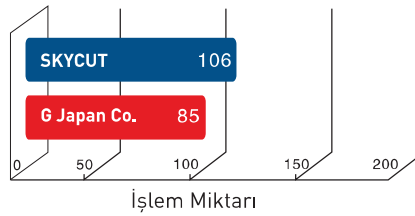

Kesme parametreleri  
VC= 160 m / min.  
f= 0.16 mm / r  
ap= 1.5 mm

Kesim Ömrü  
**+25%**

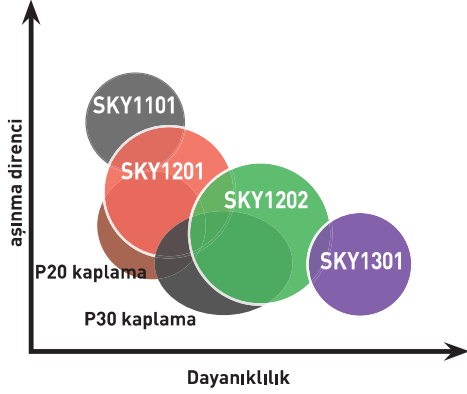

### SKY1201

- TiCN ile alt katman kombinasyonu kalın Al<sub>2</sub>O<sub>3</sub> katmanı ve Tin den üretilmiş kaplama ile birlikte mükemmel aşınma direnci. Yarı kaba çelik operasyonları için uygundur.

### SKY1202

- Yeni jenerasyon kalın katman a-Al<sub>2</sub>O<sub>3</sub> kaplama anti plastik deformasyonu iyice geliştirilmiş güçlü performans optimizasyonu sayesinde yaygın olarak kullanım.

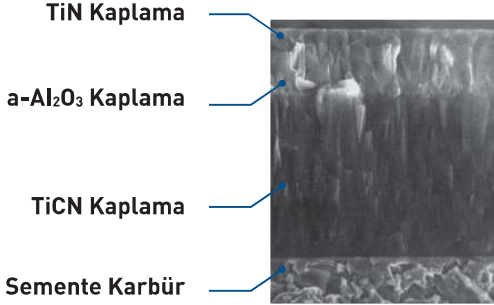

Geleneksel CVD kaplama ile kıyasladığımızda yeni a-Al<sub>2</sub>O<sub>3</sub> kaplama tekniğiyle uçların daha güçlü ve daha fazla aşınma direncine sahiptir.

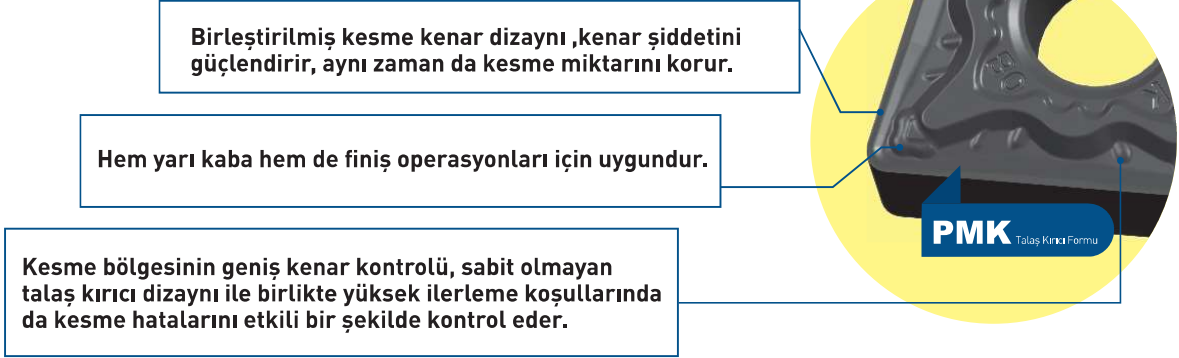

### Örnek Deneme

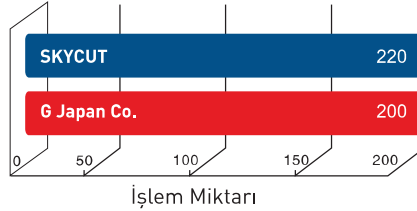

Kesme parametreleri  
VC= 220 m / min.  
f= 0.25 mm / r  
ap= 2 mm



### DÖKÜM KALİTELERİ



#### SKY3152

- Geliştirilmiş CVD kalitesi  $Al_2O_3$  + Kalın TiCN alt katmanı geliştirilmiş kaplama ile yeni materyaller birleştirilmiştir. Gri dökme demir için mükemmel çalışma iyi aşınma direnci ultra iyi tanecik yüksek yüzey kalitesi ve yüksek boyutsal hassasiyet sağlar.

#### SKY3202

- Geliştirilmiş CVD kalitesi  $Al_2O_3$  + KalınTiCN alt katmanı geliştirilmiş kaplama kombinasyonu ile dökme demir parçalarında darbe performansı arttırıldı. Yüksek hızda ki sfero döküm işlemler için uygun bir kalitedir.



#### SKY3203

- Yeni birleştirilmiş kaplama kalitesi; (Tin + Kalın  $Al_2O_3$  + Kalın TiCN), aşınma direnci ile birlikte göz alıcı aşınma direnci ve uçların kuvveti sağlanmıştır. Dökme demir ve sfero döküm materyallerinde kullanımı uygundur.

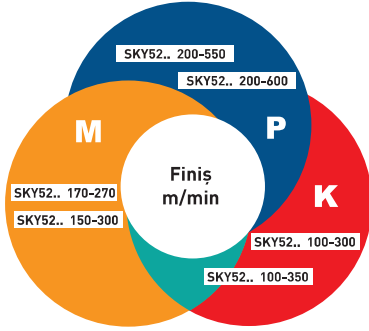

Kaba işlemler için yeni talaş kırıcılar birşik ön çaplı dizayn kenarların stabilitesini güçlendiren mükemmel materyal alt katmanı. Aynı zamanda farklı materyallerin kaba işlemi için yüksek kesme performansına sahiptir.



### SERMET İÇİN KAPLAMA ÖZELLİKLERİ

- İyi dizayn edilmiş bileşim geliştirilmiş 52.. kalite ile yüksek sıcaklık kapasitesi.

- Isı iletkenliği ve termal titreşim direnci.

- Gelişmiş ultra iyi yapı üretimi sayesinde ürün kalite stabilitesi (SKY52..) yüksek olan PVD kaplama kullanılır.



### Örnek Deneme

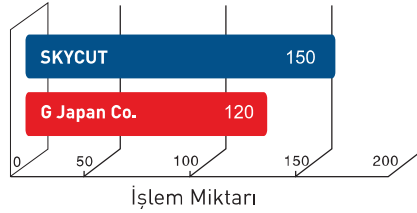

Kesme parametreleri  
VC= 260 m / min.  
f= 0.8-1.00 mm / r  
ap= 0.2 mm



### NL / AU SERİSİ - ALÜMİNYUM

- Yeni parlatma (polisaj) işlemi
- Keskin kenar
- Üstün aşınma direnci
- Talaş ve talaş dökülme istikrarı
- Yavaş kesme direnci ,deformasyonu önlemek için
- Yüzey istenilen parçalar için mükemmel kalite



### Örnek Deneme - 1

	
İş Parçası	A356
Operasyon	Kaba Talaş Tornalama
Uç	WNGG080408-NL / <b>SKY9115</b>

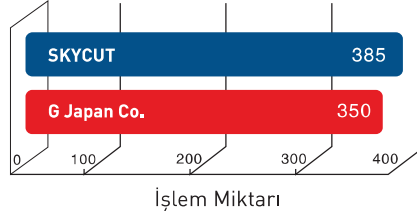

Kesme parametreleri  
VC= 500 m / min.  
f= 0,5 mm / r  
ap= 1,5 mm



Kesim Ömrü  
**+10%**

### Örnek Deneme - 2

	
İş Parçası	A356
Operasyon	İç Çap Tornalama
Uç	CCGT09T304-AU / <b>SKY1200</b>

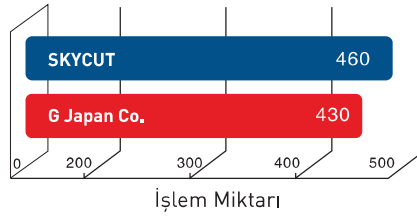

Kesme parametreleri  
VC= 460 m / min.  
f= 0,16 mm / r  
ap= 0,8 mm



Kesim Ömrü  
**+7%**



### CBN

- Sinterlenmiş integral PCBN uç.
- Kaba, yarı kaba ve ince işleme için geniş uygulanabilirlik.
- Devamlı, yarı kesintili ve kesintili kesim için uygundur.
- Daha fazla kesme kenarı yüksek takım ömrü kullanımı
- Yüksek bükülme gücü yüksek ve derin kesim için uygundur.



### PCBN

- Kaba, yarı kaba ve ince işlem yapılabilir .
- Yüksek kaynaklama gücüne sahiptir. 3 mm den kısa kesme derinliğine sahiptir. Devamlı, yarı kesintili ve kesintili kesimde uygundur.
- Merkez derinliği pozisyonlandırılabilir. Vida delikleri kullanıcıların ihtiyaçlarına göre dizayn edilebilir.

### PCBN - ALAŞIMLI KAYNAK UÇLAR

- Merkez derinliği pozisyonlandırılabilir.
- Vida delikleri kullanıcıların ihtiyaçlarına göre dizayn edilebilir.



### ENTEĞRE EDİLMİŞ ALAŞIM - PCBN UÇ

- Entegre edilmiş pcbn bıçak birleştirilebilir.
- Alaşım katman yüksek güce sahip alt katman ile birleştirilebilir.
- 0-5 mm kesme derinliğine uygun olup ,devamlı ve hafif kesintili kesimde kullanılır .

**CN..**

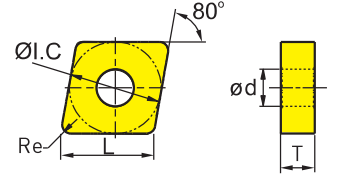

Uç Şekli	Tip	Ölçüler / Boyut (mm)				Kaplama Seçimi								
		ØI.C	T	Ød	Re	SKY1100	SKY1200	SKY1300	SKY1330	SKY2225	SKY4010	SKY4025	SKY5280	SKY5230
	CNMG090304-PMK	9,525	3,18	3,81	0,4	●	▲	▲	●	●	●	●	●	●
	CNMG090308-PMK	9,525	3,18	3,81	0,8	●	▲	▲	●	●	●	●	●	●
	CNMG120404-PMK	12,7	4,76	5,16	0,4	●	▲	▲	●	●	▲	▲	●	●
	CNMG120408-PMK	12,7	4,76	5,16	0,8	●	▲	▲	●	●	▲	▲	●	●
	CNMG120412-PMK	12,7	4,76	5,16	1,2	●	▲	▲	●	●	▲	▲	●	●
	CNMG120416-PMK	12,7	4,76	5,16	1,6	●	▲	▲	●	●	▲	▲	●	●
	CNMG160608-PMK	16,1	6,35	6,35	0,8	●	▲	▲	●	●	▲	▲	●	●
	CNMG160612-PMK	16,1	6,35	6,35	1,2	●	▲	▲	●	●	▲	▲	●	●
	CNMG160616-PMK	16,1	6,35	6,35	1,6	●	▲	▲	●	●	▲	▲	●	●
	CNMG190612-PMK	19,05	6,35	7,94	1,2	●	▲	▲	●	●	●	●	●	●
CNMG190616-PMK	19,05	6,35	7,94	1,6	●	▲	▲	●	●	●	●	●	●	
	CNMG120404L/R-X	12,7	4,76	5,16	0,4	●	▲	▲	●	●	●	●	●	
	CNMG120408L/R-X	12,7	4,76	5,16	0,8	●	▲	▲	●	●	●	●	●	
	CNMG120412L/R-X	12,7	4,76	5,16	1,2	●	▲	▲	●	●	●	●	●	
	CNMG120404	12,7	4,76	5,16	0,4	●	▲	▲	●	●	●	●	●	
	CNMG120408	12,7	4,76	5,16	0,8	●	▲	▲	●	●	●	●	●	
	CNMG120412	12,7	4,76	5,16	1,2	●	▲	▲	●	●	●	●	●	

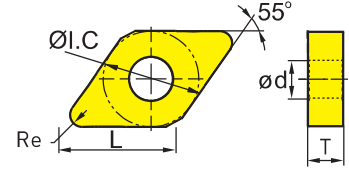

▲ Önerilen kalite (Sürekli stok) ● Sipariş üzerine

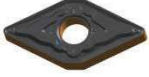
**DN..**

Uç Şekli	Tip	Ölçüler / Boyut (mm)				Kaplama Seçimi								
		ØI.C	T	Ød	Re	SKY1100	SKY1200	SKY1300	SKY1330	SKY2225	SKY4010	SKY4025	SKY5280	SKY5230
	DNMG110404-PMK	9,525	4,76	3,81	0,4	●	▲	▲	●	●	●	●	●	●
	DNMG110408-PMK	9,525	4,76	3,81	0,8	●	▲	▲	●	●	●	●	●	●
	DNMG150404-PMK	12,7	4,76	5,16	0,4	●	●	●	●	●	●	●	●	●
	DNMG150408-PMK	12,7	4,76	5,16	0,8	●	●	●	●	●	●	●	●	●
	DNMG150412-PMK	12,7	4,76	5,16	1,2	●	●	●	●	●	●	●	●	●
	DNMG150604-PMK	12,7	6,35	5,16	0,4	●	▲	▲	●	●	▲	▲	●	●
	DNMG150608-PMK	12,7	6,35	5,16	0,8	●	▲	▲	●	●	▲	▲	●	●
	DNMG150612-PMK	12,7	6,35	5,16	1,2	●	▲	▲	●	●	▲	▲	●	●

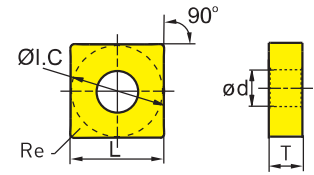
▲ Önerilen kalite (Sürekli stok) ● Sipariş üzerine

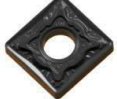
**SN..**

Uç Şekli	Tip	Ölçüler / Boyut (mm)				Kaplama Seçimi								
		ØI.C	T	Ød	Re	SKY1100	SKY1200	SKY1300	SKY1330	SKY2225	SKY4010	SKY4025	SKY5280	SKY5230
	SNMG090304-PMK	9,525	3,18	3,81	0,4	●	▲	▲	●	●	●	●	●	●
	SNMG090308-PMK	9,525	3,18	3,81	0,8	●	▲	▲	●	●	●	●	●	●
	SNMG120404-PMK	12,7	4,76	5,16	0,4	●	▲	▲	●	●	▲	▲	●	●
	SNMG120408-PMK	12,7	4,76	5,16	0,8	●	▲	▲	●	●	▲	▲	●	●
	SNMG120412-PMK	12,7	4,76	5,16	1,2	●	▲	▲	●	●	▲	▲	●	●
	SNMG150612-PMK	15,878	6,35	6,35	1,2	●	▲	▲	●	●	●	●	●	●
	SNMG190612-PMK	19,05	6,35	6,35	1,2	●	▲	▲	●	●	●	●	●	●
	SNMG190616-PMK	19,05	6,35	7,94	1,2	●	▲	▲	●	●	●	●	●	●
	SNMG120404L/R-X	12,7	4,76	5,16	0,4	●	▲	▲	●	●	●	●	●	●
	SNMG120408L/R-X	12,7	4,76	5,16	0,8	●	▲	▲	●	●	●	●	●	●
	SNMG120412L/R-X	12,7	4,76	5,16	1,2	●	▲	▲	●	●	●	●	●	●
	SNMG120404	12,7	4,76	5,16	0,4	●	▲	▲	●	●	●	●	●	●
	SNMG120408	12,7	4,76	5,16	0,8	●	▲	▲	●	●	●	●	●	●
	SNMG120412	12,7	4,76	5,16	1,2	●	▲	▲	●	●	●	●	●	●

▲ Önerilen kalite (Sürekli stok) ● Sipariş üzerine

**TN..**

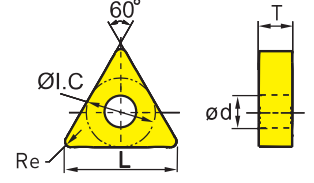

Uç Şekli	Tip	Ölçüler / Boyut (mm)				Kaplama Seçimi								
		ØI.C	T	Ød	Re	SKY1100	SKY1200	SKY1300	SKY1330	SKY2225	SKY4010	SKY4025	SKY5280	SKY5230
	TNMG160404-PMK	9.525	4.76	3.81	0.4	●	▲	▲	●	●	▲	▲	●	●
	TNMG160408-PMK	9.525	4.76	3.81	0.8	●	▲	▲	●	●	▲	▲	●	●
	TNMG160412-PMK	9.525	4.76	3.81	1.2	●	▲	▲	●	●	▲	▲	●	●
	TNMG220404-PMK	12.7	4.76	5.16	0.4	●	▲	▲	●	●	●	●	●	●
	TNMG220408-PMK	12.7	4.76	5.16	0.8	●	▲	▲	●	●	●	●	●	●
	TNMG220412-PMK	12.7	4.76	5.16	1.2	●	▲	▲	●	●	●	●	●	●
	TNMG160404-PR	9.525	4.76	3.81	0.4	●	▲	▲	●	●	●	●	●	●
	TNMG160408-PR	9.525	4.76	3.81	0.8	●	▲	▲	●	●	●	●	●	●
	TNMG160412-PR	9.525	4.76	3.81	1.2	●	▲	▲	●	●	●	●	●	●
	TNMG160404L/R-X	9.525	4.76	3.81	0.4	●	▲	▲	●	●	●	●	●	●
	TNMG160408L/R-X	9.525	4.76	3.81	0.8	●	▲	▲	●	●	●	●	●	●
	TNMG160412L/R-X	9.525	4.76	3.81	1.2	●	▲	▲	●	●	●	●	●	●
	TNMG160404	9.525	4.76	3.81	0.4	●	▲	▲	●	●	●	●	●	●
	TNMG160408	9.525	4.76	3.81	0.8	●	▲	▲	●	●	●	●	●	●
	TNMG160412	9.525	4.76	3.81	1.2	●	▲	▲	●	●	●	●	●	●

▲ Önerilen kalite [Sürekli stok] ● Sipariş üzerine

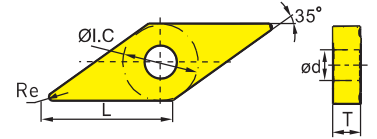



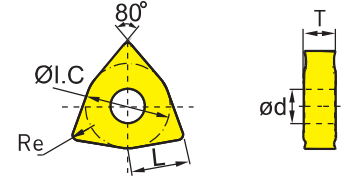

**VN..**

Uç Şekli	Tip	Ölçüler / Boyut (mm)				Kaplama Seçimi								
		ØI.C	T	Ød	Re	SKY1100	SKY1200	SKY1300	SKY1330	SKY2225	SKY4010	SKY4025	SKY5280	SKY5230
	VNMG160404-PMK	9.525	4.76	3.81	0.4	●	▲	▲	●	●	▲	▲	●	●
	VNMG160408-PMK	9.525	4.76	3.81	0.8	●	▲	▲	●	●	▲	▲	●	●
	VNMG160412-PMK	9.525	4.76	3.81	1.2	●	▲	▲	●	●	▲	▲	●	●
	VNMG160404	9.525	4.76	3.81	0.4	●	●	●	●	●	●	●	●	●
	VNMG160408	9.525	4.76	3.81	0.8	●	●	●	●	●	●	●	●	●
	VNMG160412	9.525	4.76	3.81	1.2	●	●	●	●	●	●	●	●	●

▲ Önerilen kalite [Sürekli stok] ● Sipariş üzerine

**WN..**

Uç Şekli	Tip	Ölçüler / Boyut (mm)				Kaplama Seçimi								
		ØI.C	T	Ød	Re	SKY1100	SKY1200	SKY1300	SKY1330	SKY2225	SKY4010	SKY4025	SKY5280	SKY5230
	WNMG060408-PMK	9,525	4,76	3,81	0,8	●	▲	▲	●	●	▲	▲	●	●
	WNMG060412-PMK	9,525	4,76	3,81	1,2	●	▲	▲	●	●	▲	▲	●	●
	WNMG080404-PMK	12,7	4,76	5,16	0,4	●	▲	▲	●	●	▲	▲	●	●
	WNMG080408-PMK	12,7	4,76	5,16	0,8	●	▲	▲	●	●	▲	▲	●	●
	WNMG080412-PMK	12,7	4,76	5,16	1,2	●	▲	▲	●	●	▲	▲	●	●
	WNMG080404-PR	12,7	4,76	5,16	0,4	●	▲	▲	●	●	●	●	●	●
	WNMG080408-PR	12,7	4,76	5,16	0,8	●	▲	▲	●	●	●	●	●	●
	WNMG080412-PR	12,7	4,76	5,16	1,2	●	▲	▲	●	●	●	●	●	●
	WNMG080404L/R-X	12,7	4,76	5,16	0,4	●	▲	▲	●	●	●	●	●	●
	WNMG080408L/R-X	12,7	4,76	5,16	0,8	●	▲	▲	●	●	●	●	●	●
	WNMG080412L/R-X	12,7	4,76	5,16	1,2	●	▲	▲	●	●	●	●	●	●
	WNMG080404	12,7	4,76	5,16	0,4	●	▲	▲	●	●	●	●	●	●
	WNMG080408	12,7	4,76	5,16	0,8	●	▲	▲	●	●	●	●	●	●
	WNMG080412	12,7	4,76	5,16	1,2	●	▲	▲	●	●	●	●	●	●

▲ Önerilen kalite (Sürekli stok) ● Sipariş üzerine

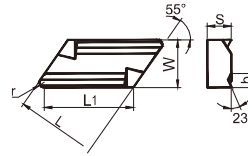
**KNUX**

Uç Şekli	Tip	Ölçüler / Boyut (mm)					Kaplama Seçimi		
		L	D	S	d1	R	SKY1100	SKY1200	SKY1300
	KNUX160405L11	16	16,15	9,525	4,76	0,5	●	▲	●
	KNUX160410L11	16	16,15	9,525	4,76	1,0	●	▲	●
	KNUX160405L12	16	16,15	9,525	4,76	0,5	●	▲	●
	KNUX160410L12	16	16,15	9,525	4,76	1,0	●	▲	●
	KNUX160405R11	16	16,15	9,525	4,76	0,5	●	▲	●
	KNUX160410R11	16	16,15	9,525	4,76	1,0	●	▲	●
	KNUX160405R12	16	16,15	9,525	4,76	0,5	●	▲	●
	KNUX160410R12	16	16,15	9,525	4,76	1,0	●	▲	●

▲ Önerilen kalite (Sürekli stok) ● Sipariş üzerine

**CC..**

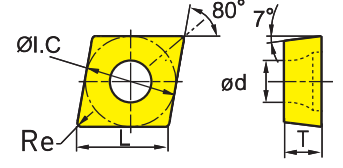

Uç Şekli	Tip	Ölçüler / Boyut (mm)				Kaplama Seçimi								
		ØI.C	T	Ød	Re	SKY1100	SKY1200	SKY1300	SKY1330	SKY2225	SKY4010	SKY4025	SKY5280	SKY5230
	CCMT060204-PMK	6.35	2.38	2.8	0.4	●	▲	▲	●	●	●	●	●	●
	CCMT060208-PMK	6.35	2.38	2.8	0.8	●	▲	▲	●	●	●	●	●	●
	CCMT09T304-PMK	9.525	3.97	4.4	0.4	●	▲	▲	●	●	●	●	●	●
	CCMT09T308-PMK	9.525	3.97	4.4	0.8	●	▲	▲	●	●	●	●	●	●
	CCMT120404-PMK	12.7	4.76	5.56	0.4	●	▲	▲	●	●	●	●	●	●
	CCMT120408-PMK	12.7	4.76	5.56	0.8	●	▲	▲	●	●	●	●	●	●

▲ Önerilen kalite (Sürekli stok) ● Sipariş üzerine

**DC..**

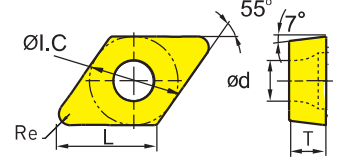

Uç Şekli	Tip	Ölçüler / Boyut (mm)				Kaplama Seçimi								
		ØI.C	T	Ød	Re	SKY1100	SKY1200	SKY1300	SKY1330	SKY2225	SKY4010	SKY4025	SKY5280	SKY5230
	DCMT070204-PMK	6.35	2.38	2.8	0.4	●	▲	▲	●	●	●	●	●	●
	DCMT070208-PMK	6.35	2.38	2.8	0.8	●	▲	▲	●	●	●	●	●	●
	DCMT11T304-PMK	9.525	3.97	4.4	0.4	●	▲	▲	●	●	●	●	●	●
	DCMT11T308-PMK	9.525	3.97	4.4	0.8	●	▲	▲	●	●	●	●	●	●
	DCMT11T312-PMK	9.525	3.97	4.4	1.2	●	▲	▲	●	●	●	●	●	●

▲ Önerilen kalite (Sürekli stok) ● Sipariş üzerine

**SC..**

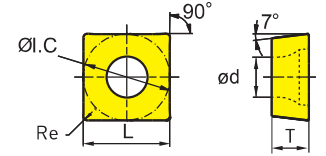

Uç Şekli	Tip	Ölçüler / Boyut (mm)				Kaplama Seçimi								
		ØI.C	T	Ød	Re	SKY1100	SKY1200	SKY1300	SKY1330	SKY2225	SKY4010	SKY4025	SKY5280	SKY5230
	SCMT09T304-PMK	9.525	3.97	4.4	0.4	●	▲	▲	●	●	●	●	●	●
	SCMT09T308-PMK	9.525	3.97	4.4	0.8	●	▲	▲	●	●	●	●	●	●
	SCMT120404-PMK	12.7	4.76	5.56	0.4	●	▲	▲	●	●	●	●	●	●
	SCMT120408-PMK	12.7	4.76	5.56	0.8	●	▲	▲	●	●	●	●	●	●
	SCMT120412-PMK	12.7	4.76	5.56	1.2	●	▲	▲	●	●	●	●	●	●

▲ Önerilen kalite (Sürekli stok) ● Sipariş üzerine

## TC..

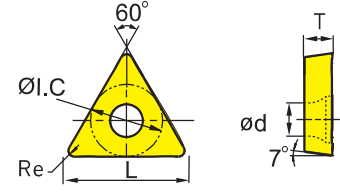

Uç Şekli	Tip	Ölçüler / Boyut (mm)				Kaplama Seçimi								
		ØI.C	T	Ød	Re	SKY1100	SKY1200	SKY1300	SKY1330	SKY2225	SKY4010	SKY4025	SKY5280	SKY5230
	TCMT090204-PMK	5,6	2,38	2,5	0,4	●	▲	▲	●	●	●	●	●	●
	TCMT090208-PMK	5,6	2,38	2,5	0,8	●	▲	▲	●	●	●	●	●	●
	TCMT110204-PMK	6,35	2,38	2,8	0,4	●	▲	▲	●	●	●	●	●	●
	TCMT110208-PMK	6,35	2,38	2,8	0,4	●	▲	▲	●	●	●	●	●	●
	TCMT16T304-PMK	9,525	3,97	4,4	0,4	●	▲	▲	●	●	●	●	●	●
	TCMT16T308-PMK	9,525	3,97	4,4	0,8	●	▲	▲	●	●	●	●	●	●

▲ Önerilen kalite (Sürekli stok) ● Sipariş üzerine

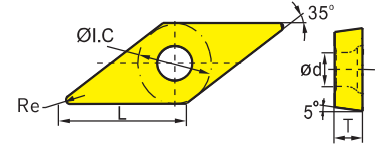

## VB..

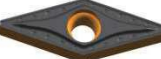
Uç Şekli	Tip	Ölçüler / Boyut (mm)				Kaplama Seçimi								
		ØI.C	T	Ød	Re	SKY1100	SKY1200	SKY1300	SKY1330	SKY2225	SKY4010	SKY4025	SKY5280	SKY5230
	VBMT160404-PMK	9,525	4,76	4,4	0,4	●	▲	▲	●	●	●	●	●	●
	VBMT160408-PMK	9,525	4,76	4,4	0,8	●	▲	▲	●	●	●	●	●	●
	VBMT160412-PMK	9,525	4,76	4,4	1,2	●	▲	▲	●	●	●	●	●	●

▲ Önerilen kalite (Sürekli stok) ● Sipariş üzerine

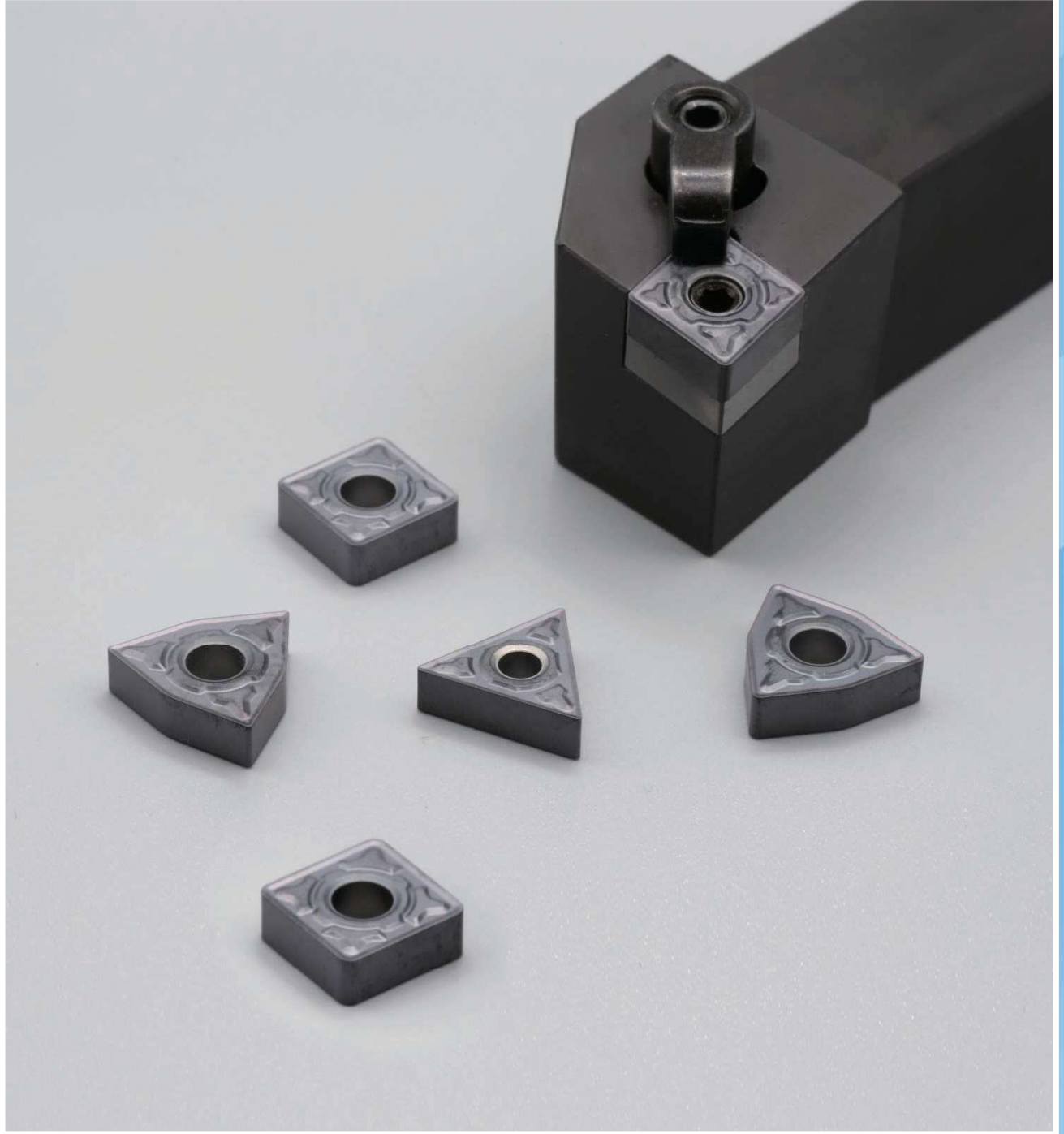

**Genel Torna Uçları - Paslanmaz Çelik**

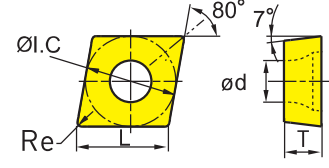

**CN..**

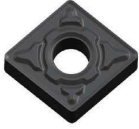
Uç Şekli	Tip	Ölçüler / Boyut (mm)				Kaplama Seçimi								
		ØI.C	T	Ød	Re	SKY8280	SKY8200	SKY8100	SKY8300	SKY8290	SKY3125	SKY4125	SKY5280	SKY5230
	CNMG090304-MM	9,525	3,18	3,81	0,4	▲	▲	●	●	●	●	●	●	●
	CNMG090308-MM	9,525	3,18	3,81	0,8	▲	▲	●	●	●	●	●	●	●
	CNMG120404-MM	12,7	4,76	5,16	0,4	▲	▲	●	●	●	●	▲	●	●
	CNMG120408-MM	12,7	4,76	5,16	0,8	▲	▲	●	●	●	●	▲	●	●
	CNMG120412-MM	12,7	4,76	5,16	1,2	▲	▲	●	●	●	●	▲	●	●

▲ Önerilen kalite (Sürekli stok) ● Sipariş üzerine

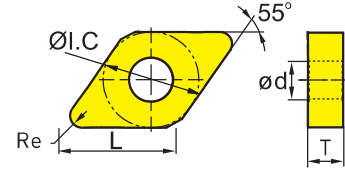
**DN..**

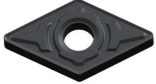
Uç Şekli	Tip	Ölçüler / Boyut (mm)				Kaplama Seçimi								
		ØI.C	T	Ød	Re	SKY8280	SKY8200	SKY8100	SKY8300	SKY8290	SKY3125	SKY4125	SKY5280	SKY5230
	DNMG110404-MM	9,525	4,76	3,81	0,4	▲	▲	●	●	●	●	▲	●	●
	DNMG110408-MM	9,525	4,76	3,81	0,8	▲	▲	●	●	●	●	▲	●	●
	DNMG150404-MM	12,7	4,76	5,16	0,4	●	●	●	●	●	●	●	●	●
	DNMG150408-MM	12,7	4,76	5,16	0,8	●	●	●	●	●	●	●	●	●
	DNMG150412-MM	12,7	4,76	5,16	1,2	●	●	●	●	●	●	●	●	●
	DNMG150604-MM	12,7	6,35	5,16	0,4	▲	▲	●	●	●	●	▲	●	●
	DNMG150608-MM	12,7	6,35	5,16	0,8	▲	▲	●	●	●	●	▲	●	●
	DNMG150612-MM	12,7	6,35	5,16	1,2	▲	▲	●	●	●	●	▲	●	●

▲ Önerilen kalite (Sürekli stok) ● Sipariş üzerine

## GENEL TORNA UÇLARI - PASLANMAZ ÇELİK



### SN..

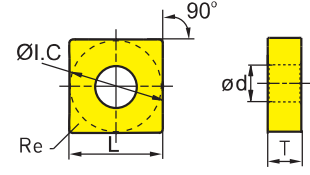

Uç Şekli	Tip	Ölçüler / Boyut (mm)				Kaplama Seçimi								
		ØI.C	T	ød	Re	SKY8280	SKY8200	SKY8100	SKY8300	SKY8290	SKY3125	SKY4125	SKY5280	SKY5230
	SNMG090304-MM	9,525	3,18	3,81	0,4	▲	▲	●	●	●	●	●	●	●
	SNMG090308-MM	9,525	3,18	3,81	0,8	▲	▲	●	●	●	●	●	●	●
	SNMG120404-MM	12,7	4,76	5,16	0,4	▲	▲	●	●	●	●	▲	●	●
	SNMG120408-MM	12,7	4,76	5,16	0,8	▲	▲	●	●	●	●	▲	●	●
	SNMG120412-MM	12,7	4,76	5,16	1,2	▲	▲	●	●	●	●	▲	●	●

▲ Önerilen kalite (Sürekli stok) ● Sipariş üzerine

### TN..

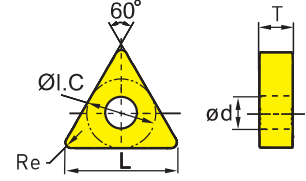

Uç Şekli	Tip	Ölçüler / Boyut (mm)				Kaplama Seçimi								
		ØI.C	T	ød	Re	SKY8280	SKY8200	SKY8100	SKY8300	SKY8290	SKY3125	SKY4125	SKY5280	SKY5230
	TNMG160404-MM	9,525	4,76	3,81	0,4	▲	▲	●	●	●	●	▲	●	●
	TNMG160408-MM	9,525	4,76	3,81	0,8	▲	▲	●	●	●	●	▲	●	●
	TNMG160412-MM	9,525	4,76	3,81	1,2	▲	▲	●	●	●	●	▲	●	●
	TNMG220404-MM	12,7	4,76	5,16	0,4	▲	▲	●	●	●	●	●	●	●
	TNMG220408-MM	12,7	4,76	5,16	0,8	▲	▲	●	●	●	●	●	●	●
	TNMG220412-MM	12,7	4,76	5,16	1,2	▲	▲	●	●	●	●	●	●	●

▲ Önerilen kalite (Sürekli stok) ● Sipariş üzerine

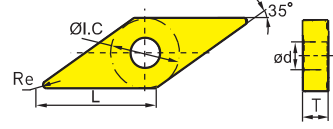
**VN..**

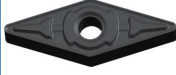
Uç Şekli	Tip	Ölçüler / Boyut (mm)				Kaplama Seçimi								
		ØI.C	T	Ød	Re	SKY8280	SKY8200	SKY8100	SKY8300	SKY8290	SKY3125	SKY4125	SKY5280	SKY5230
	VNMG160404-MM	9,525	4,76	3,81	0,4	▲	▲	●	●	●	●	▲	●	●
	VNMG160408-MM	9,525	4,76	3,81	0,8	▲	▲	●	●	●	●	▲	●	●
	VNMG160412-MM	9,525	4,76	3,81	1,2	▲	▲	●	●	●	●	▲	●	●

▲ Önerilen kalite (Sürekli stok) ● Sipariş üzerine

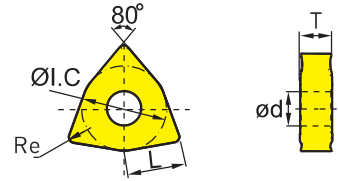
**WN..**

Uç Şekli	Tip	Ölçüler / Boyut (mm)				Kaplama Seçimi								
		ØI.C	T	Ød	Re	SKY8280	SKY8200	SKY8100	SKY8300	SKY8290	SKY3125	SKY4125	SKY5280	SKY5230
	WNMG060408-MM	9,525	4,76	3,81	0,8	▲	▲	●	●	●	●	●	●	●
	WNMG060412-MM	9,525	4,76	3,81	1,2	▲	▲	●	●	●	●	●	●	●
	WNMG080404-MM	12,7	4,76	5,16	0,4	▲	▲	●	●	●	▲	▲	●	●
	WNMG080408-MM	12,7	4,76	5,16	0,8	▲	▲	●	●	●	▲	▲	●	●
	WNMG080412-MM	12,7	4,76	5,16	1,2	▲	▲	●	●	●	▲	▲	●	●

▲ Önerilen kalite (Sürekli stok) ● Sipariş üzerine

**CC..**

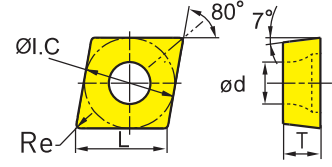

Uç Şekli	Tip	Ölçüler / Boyut (mm)				Kaplama Seçimi								
		ØI.C	T	Ød	Re	SKY8280	SKY8200	SKY8100	SKY8300	SKY8290	SKY3125	SKY4125	SKY5280	SKY5230
	CCMT060202-MM	6.35	2.38	2.8	0.2	▲	▲	●	●	●	●	▲	●	●
	CCMT060204-MM	6.35	2.38	2.8	0.4	▲	▲	●	●	●	●	▲	●	●
	CCMT09T302-MM	9.525	3.97	4.4	0.2	▲	▲	●	●	●	●	▲	●	●
	CCMT09T304-MM	9.525	3.97	4.4	0.4	▲	▲	●	●	●	●	▲	●	●
	CCMT09T308-MM	12.7	4.76	5.56	0.8	▲	▲	●	●	●	●	▲	●	●
	CCMT120404-MM	12.7	4.76	5.56	0.4	▲	▲	●	●	●	●	▲	●	●
	CCMT120408-MM	12.7	4.76	5.56	0.8	▲	▲	●	●	●	●	▲	●	●

▲ Önerilen kalite (Sürekli stok) ● Sipariş üzerine

**DC..**

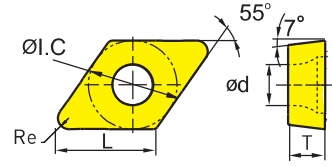

Uç Şekli	Tip	Ölçüler / Boyut (mm)				Kaplama Seçimi								
		ØI.C	T	Ød	Re	SKY8280	SKY8200	SKY8100	SKY8300	SKY8290	SKY3125	SKY4125	SKY5280	SKY5230
	DCMT070202-MM	6.35	2.38	2.8	0.2	▲	▲	●	●	●	●	▲	●	●
	DCMT070204-MM	6.35	2.38	2.8	0.4	▲	▲	●	●	●	●	▲	●	●
	DCMT070208-MM	9.525	3.97	4.4	0.8	▲	▲	●	●	●	●	▲	●	●
	DCMT11T302-MM	9.525	3.97	4.4	0.2	▲	▲	●	●	●	●	▲	●	●
	DCMT11T304-MM	9.525	3.97	4.4	0.4	▲	▲	●	●	●	●	▲	●	●
	DCMT11T308-MM	9.525	3.97	4.4	0.8	▲	▲	●	●	●	●	▲	●	●

▲ Önerilen kalite (Sürekli stok) ● Sipariş üzerine

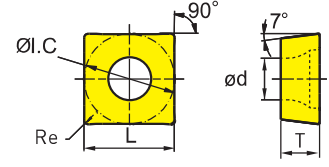

## SC..

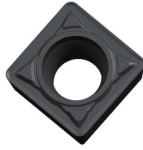
Uç Şekli	Tip	Ölçüler / Boyut (mm)				Kaplama Seçimi								
		ØI.C	T	Ød	Re	SKY8280	SKY8200	SKY8100	SKY8300	SKY8290	SKY3125	SKY4125	SKY5280	SKY5230
	SCMT09T302-MM	9.525	3.97	4.4	0.2	▲	▲	●	●	●	●	▲	●	●
	SCMT09T304-MM	9.525	3.97	4.4	0.4	▲	▲	●	●	●	●	▲	●	●
	SCMT09T308-MM	12.7	4.76	5.56	0.8	▲	▲	●	●	●	●	▲	●	●
	SCMT120404-MM	12.7	4.76	5.56	0.4	▲	▲	●	●	●	●	▲	●	●
	SCMT120408-MM	12.7	4.76	5.56	0.8	▲	▲	●	●	●	●	▲	●	●
	SCMT120412-MM	12.7	4.76	5.56	1.2	▲	▲	●	●	●	●	▲	●	●

▲ Önerilen kalite (Sürekli stok) ● Sipariş üzerine

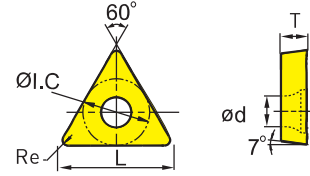

## TC..

Uç Şekli	Tip	Ölçüler / Boyut (mm)				Kaplama Seçimi								
		ØI.C	T	Ød	Re	SKY8280	SKY8200	SKY8100	SKY8300	SKY8290	SKY3125	SKY4125	SKY5280	SKY5230
	TCMT090202-MM	5.6	2.38	2.5	0.2	▲	▲	●	●	●	●	▲	●	●
	TCMT090204-MM	5.6	2.38	2.5	0.4	▲	▲	●	●	●	●	▲	●	●
	TCMT110202-MM	6.35	2.38	2.8	0.2	▲	▲	●	●	●	●	▲	●	●
	TCMT110204-MM	6.35	2.38	2.8	0.4	▲	▲	●	●	●	●	▲	●	●
	TCMT110208-MM	6.35	3.97	4.4	0.8	▲	▲	●	●	●	●	▲	●	●
	TCMT16T304-MM	9.525	3.97	4.4	0.4	▲	▲	●	●	●	●	▲	●	●
	TCMT16T308-MM	9.525	3.97	4.4	0.8	▲	▲	●	●	●	●	▲	●	●

▲ Önerilen kalite (Sürekli stok) ● Sipariş üzerine

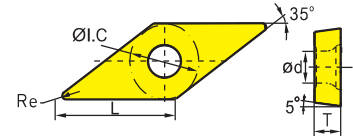

## VB..

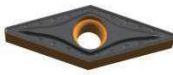
Uç Şekli	Tip	Ölçüler / Boyut (mm)				Kaplama Seçimi								
		ØI.C	T	Ød	Re	SKY8280	SKY8200	SKY8100	SKY8300	SKY8290	SKY3125	SKY4125	SKY5280	SKY5230
	VBMT160404-MM	9.525	4.76	4.4	0.4	▲	▲	●	●	●	●	▲	●	●
	VBMT160408-MM	9.525	4.76	4.4	0.8	▲	▲	●	●	●	●	▲	●	●
	VBMT160412-MM	9.525	4.76	4.4	1.2	▲	▲	●	●	●	●	▲	●	●



▲ Önerilen kalite (Sürekli stok) ● Sipariş üzerine

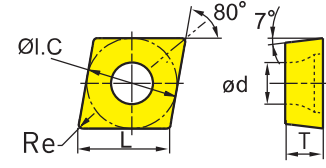

**Genel Torna Uçları - Döküm**



## CN..

Uç Şekli	Tip	Ölçüler / Boyut (mm)				Kaplama Seçimi					
		ØI.C	T	ød	Re	SKY2225	SKY3510	SKY3260	SKY3220	SKY5280	SKY5230
	CNMG120404	12.7	3.18	3.81	0.4	▲	●	▲	●	▲	●
	CNMG120408	12.7	3.18	3.81	0.8	▲	●	▲	●	▲	●
	CNMG120412	12.7	4.76	5.16	1.2	▲	●	▲	●	▲	●
	CNMG120404-ZT	12.7	4.76	5.16	0.4	●	●	●	●	▲	●
	CNMG120408-ZT	12.7	4.76	5.16	0.8	●	●	●	●	▲	●
	CNMG120412-ZT	12.7	4.76	5.16	1.2	●	●	●	●	▲	●
	CNMA120404	12.7	4.76	5.16	0.4	●	●	●	●	▲	●
	CNMA120408	12.7	4.76	5.16	0.8	●	●	●	●	▲	●
	CNMA120412	12.7	4.76	5.16	1.2	●	●	●	●	▲	●

▲ Önerilen kalite (Sürekli stok) ● Sipariş üzerine

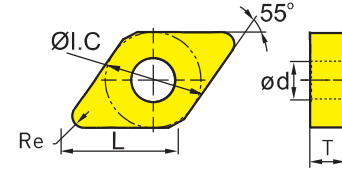

## DN..

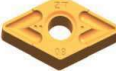
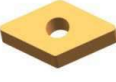
Uç Şekli	Tip	Ölçüler / Boyut (mm)				Kaplama Seçimi					
		ØI.C	T	ød	Re	SKY2225	SKY3510	SKY3260	SKY3220	SKY5280	SKY5230
	DNMG150604	12.7	6.35	5.16	0.4	▲	●	▲	●	▲	●
	DNMG150608	12.7	6.35	5.16	0.8	▲	●	▲	●	▲	●
	DNMG150612	12.7	6.35	5.16	1.2	▲	●	▲	●	▲	●
	DNMG150604-ZT	12.7	6.35	5.16	0.4	●	●	●	●	▲	●
	DNMG150608-ZT	12.7	6.35	5.16	0.8	●	●	●	●	▲	●
	DNMG150612-ZT	12.7	6.35	5.16	1.2	●	●	●	●	▲	●
	DNMA150604	12.7	6.35	5.16	0.4	●	●	●	●	▲	●
	DNMA150608	12.7	6.35	5.16	0.8	●	●	●	●	▲	●
	DNMA150612	12.7	6.35	5.16	1.2	●	●	●	●	▲	●

▲ Önerilen kalite (Sürekli stok) ● Sipariş üzerine

## SN..

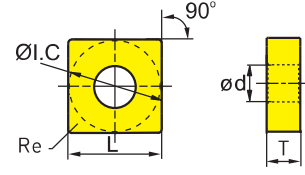

Uç Şekli	Tip	Ölçüler / Boyut (mm)				Kaplama Seçimi					
		ØI.C	T	ød	Re	SKY2225	SKY3510	SKY3260	SKY3220	SKY5280	SKY5230
	SNMG120404	12.7	4.76	5.16	0.4	▲	●	▲	●	▲	●
	SNMG120408	12.7	4.76	5.16	0.8	▲	●	▲	●	▲	●
	SNMG120412	12.7	4.76	5.16	1.2	▲	●	▲	●	▲	●
	SNMG120404-ZT	12.7	4.76	5.16	0.4	●	●	●	●	▲	●
	SNMG120408-ZT	12.7	4.76	5.16	0.8	●	●	●	●	▲	●
	SNMG120412-ZT	12.7	4.76	5.16	1.2	●	●	●	●	▲	●
	SNMA120404	12.7	4.76	5.16	0.4	●	●	●	●	▲	●
	SNMA120408	12.7	4.76	5.16	0.8	●	●	●	●	▲	●
	SNMA120412	12.7	4.76	5.16	1.2	●	●	●	●	▲	●

▲ Önerilen kalite (Sürekli stok) ● Sipariş üzerine

## TN..

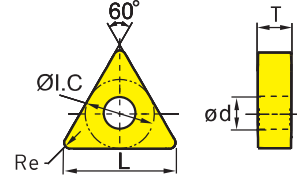



Uç Şekli	Tip	Ölçüler / Boyut (mm)				Kaplama Seçimi					
		ØI.C	T	ød	Re	SKY2225	SKY3510	SKY3260	SKY3220	SKY5280	SKY5230
	TNMG160404	9.525	4.76	3.81	0.4	▲	●	▲	●	▲	●
	TNMG160408	9.525	4.76	3.81	0.8	▲	●	▲	●	▲	●
	TNMG160412	9.525	4.76	3.81	1.2	▲	●	▲	●	▲	●
	TNMG160404-ZT	9.525	4.76	3.81	0.4	●	●	●	●	▲	●
	TNMG160408-ZT	9.525	4.76	3.81	0.8	●	●	●	●	▲	●
	TNMG160412-ZT	9.525	4.76	3.81	1.2	●	●	●	●	▲	●
	TNMA160404	9.525	4.76	3.81	0.4	●	●	●	●	▲	●
	TNMA160408	9.525	4.76	3.81	0.8	●	●	●	●	▲	●
	TNMA160412	9.525	4.76	3.81	1.2	●	●	●	●	▲	●

▲ Önerilen kalite (Sürekli stok) ● Sipariş üzerine

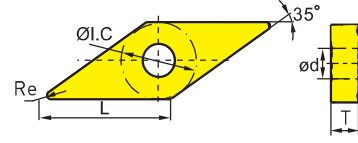



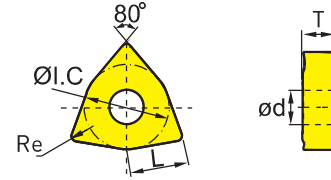

**VN..**

Uç Şekli	Tip	Ölçüler / Boyut (mm)				Kaplama Seçimi					
		ØI.C	T	Ød	Re	SKY2225	SKY3510	SKY3260	SKY3220	SKY5280	SKY5230
	VNMG160404	9.525	4.76	3.81	0.4	▲	●	▲	●	▲	●
	VNMG160408	9.525	4.76	3.81	0.8	▲	●	▲	●	▲	●
	VNMG160412	9.525	4.76	3.81	1.2	▲	●	▲	●	▲	●
	VNMG160404-ZT	9.525	4.76	3.81	0.4	●	●	●	●	▲	●
	VNMG160408-ZT	9.525	4.76	3.81	0.8	●	●	●	●	▲	●
	VNMG160412-ZT	9.525	4.76	3.81	1.2	●	●	●	●	▲	●
	VNMA160404	9.525	4.76	3.81	0.4	●	●	●	●	▲	●
	VNMA160408	9.525	4.76	3.81	0.8	●	●	●	●	▲	●
	VNMA160412	9.525	4.76	3.81	1.2	●	●	●	●	▲	●

▲ Önerilen kalite (Sürekli stok) ● Sipariş üzerine

**WN..**

Uç Şekli	Tip	Ölçüler / Boyut (mm)				Kaplama Seçimi					
		ØI.C	T	Ød	Re	SKY2225	SKY3510	SKY3260	SKY3220	SKY5280	SKY5230
	WNMG080404	12.7	4.76	5.16	0.4	▲	●	▲	●	▲	●
	WNMG080408	12.7	4.76	5.16	0.8	▲	●	▲	●	▲	●
	WNMG080412	12.7	4.76	5.16	1.2	▲	●	▲	●	▲	●
	WNMG080404-ZT	12.7	4.76	5.16	0.4	●	●	●	●	▲	●
	WNMG080408-ZT	12.7	4.76	5.16	0.8	●	●	●	●	▲	●
	WNMG080412-ZT	12.7	4.76	5.16	1.2	●	●	●	●	▲	●
	WNMA080404	12.7	4.76	5.16	0.4	●	●	●	●	▲	●
	WNMA080408	12.7	4.76	5.16	0.8	●	●	●	●	▲	●
	WNMA080412	12.7	4.76	5.16	1.2	●	●	●	●	▲	●

▲ Önerilen kalite (Sürekli stok) ● Sipariş üzerine



**Genel Torna Uçları - Alüminyum**

## CC..

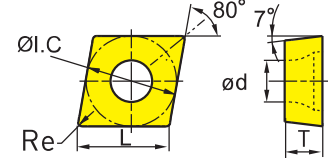

Uç Şekli	Tip	Ölçüler / Boyut (mm)				Kaplama Seçimi			
		Øl.C	T	Ød	Re	SKY2100	SKY2200	SKY5280	SKY9115
	CCMT060202K-AU	6,35	2,38	2,8	0,2	▲	●	●	▲
	CCMT060204K-AU	6,35	2,38	2,8	0,4	▲	●	●	▲
	CCMT09T302K-AU	9,525	3,97	4,4	0,8	▲	●	●	▲
	CCMT09T304K-AU	9,525	3,97	4,4	0,4	▲	●	●	▲
	CCMT09T308K-AU	9,525	3,97	4,4	0,8	▲	●	●	▲
	CCMT120404K-AU	12,7	4,76	5,56	0,4	▲	●	●	▲
	CCMT120408K-AU	12,7	4,76	5,56	0,8	▲	●	●	▲

▲ Önerilen kalite (Sürekli stok) ● Sipariş üzerine

## DC..

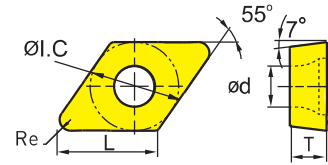

Uç Şekli	Tip	Ölçüler / Boyut (mm)				Kaplama Seçimi			
		Øl.C	T	Ød	Re	SKY2100	SKY2200	SKY5280	SKY9115
	DCGX070202K-AU	6,35	2,38	2,8	0,2	▲	●	●	▲
	DCGX070204K-AU	6,35	2,38	2,8	0,4	▲	●	●	▲
	DCGX11T302K-AU	9,525	3,97	4,4	0,2	▲	●	●	▲
	DCGX11T304K-AU	9,525	3,97	4,4	0,4	▲	●	●	▲
	DCGX11T308K-AU	9,525	3,97	4,4	0,8	▲	●	●	▲

▲ Önerilen kalite (Sürekli stok) ● Sipariş üzerine

## TC..

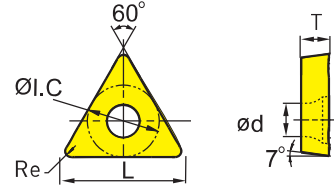

Uç Şekli	Tip	Ölçüler / Boyut (mm)				Kaplama Seçimi			
		ØI.C	T	Ød	Re	SKY2100	SKY2200	SKY5280	SKY9115
	TCGX090202K-AU	5,56	2,38	2,5	0,2	▲	●	●	▲
	TCGX090204K-AU	5,56	2,38	2,5	0,4	▲	●	●	▲
	TCGX110202K-AU	6,35	2,38	2,8	0,2	▲	●	●	▲
	TCGX110204K-AU	6,35	2,38	2,8	0,4	▲	●	●	▲
	TCGX110208K-AU	6,35	2,38	4,4	0,8	▲	●	●	▲
	TCGX16T304K-AU	9,525	3,97	4,4	0,4	▲	●	●	▲
	TCGX16T308K-AU	9,525	3,97	4,4	0,8	▲	●	●	▲

▲ Önerilen kalite (Sürekli stok) ● Sipariş üzerine

## VC..

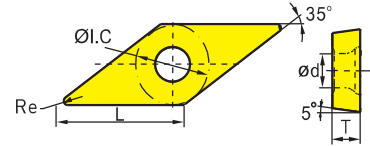

Uç Şekli	Tip	Ölçüler / Boyut (mm)				Kaplama Seçimi			
		ØI.C	T	Ød	Re	SKY2100	SKY2200	SKY5280	SKY9115
	VCGX110302K-AU	6,35	3,18	2,8	0,2	▲	●	●	▲
	VCGX110304K-AU	6,35	3,18	2,8	0,4	▲	●	●	▲
	VCGX110308K-AU	6,35	3,18	2,8	0,8	▲	●	●	▲
	VCGX160404K-AU	9,525	4,76	4,4	0,4	▲	●	●	▲
	VCGX160408K-AU	9,525	4,76	4,4	0,8	▲	●	●	▲

▲ Önerilen kalite (Sürekli stok) ● Sipariş üzerine